

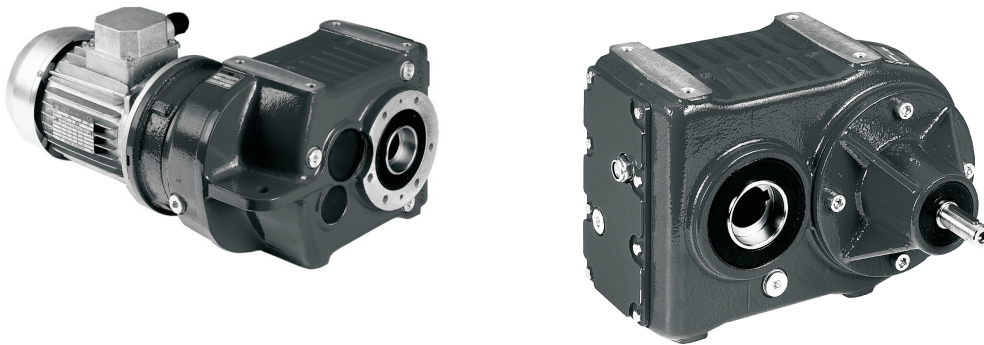

1.0 Riduttori - motoriduttori paralleli - pendolari P
 1.0 Shaft gearboxes - shaft mounted gearboxes and geared motors P
 1.0 Flach- und Aufsteckgetriebe und-Getriebemotoren P

P

1.1	Caratteristiche tecniche	<i>Technical characteristics</i>	Technische Eigenschaften	E1
1.2	Designazione	<i>Designation</i>	Bezeichnungen	E2
1.4	Lubrificazione	<i>Lubrication</i>	Schmierung	E7
1.5	Carichi radiali e assiali	<i>Axial and overhung loads</i>	Radiale und Axiale Belastungen	E8
1.6	Prestazioni riduttori	<i>Gearboxes performances</i>	Leistungen der Getriebe	E9
1.7	Prestazioni motoriduttori	<i>Gearmotors performances</i>	Leistungen der Getriebemotoren	E14
1.8	Dimensioni	<i>Dimensions</i>	Abmessungen	E22
1.9	Accessori	<i>Accessories</i>	Zubehör	E40
1.10	Linguette	<i>Keys</i>	Paßfedern	E41



63 - 71 - 90 - 112 - 125

1.1 Caratteristiche tecniche

Questi prodotti sicuramente colpiscono per la robustezza, dovuta alla realizzazione della carcassa in struttura monolitica, che abbinata alla scelta tecnica di avere solo PAM diretti più compatti, collocano il prodotto finito in una alta fascia qualitativa e prestazionale: risultano quindi perfetti per applicazioni quali traslazione carrello e scorrimento ponte.

1.1 Technical characteristics

These products strike for the robustness due to the realization of the housing in monolithic structure which, combined to the technical choice to have only direct IEC flange most compact, put the final product in a very high qualitative and performance band.

1.1 Technische Eigenschaften

Diese neuen Produkte beindrucken sicherlich durch ihre Stärke, basierend auf einem monolithischen Gehäuse in Verbindung mit der technischen Entscheidung nur direkte massive PAM zu verwenden, und führen somit zu einem hochwertigen und leistungsstarken Endprodukt.



1.2 Designazione

1.2 Designation

1.2 Bezeichnung

Maschine	Input Version	Output version	Size	Output Flange	Output Shaft	Shaft Diameter	Mounting Shaft	Rotation Sense BSTOP	Reduction ratio	Input Shaft	Designazione Motori Designation Motors Bezeichnung Motoren	Mounting positions	Position Terminal Box	WEB: Reference Designation	
00 M	01 IV	02 OV	03 SIZE	04 OF	05 OS	07 SD	08 MS	09 RS BSTOP	10 IR	12 IS		13 MP	15 PMT		
P	M	P F	63 71 90 112 125	— F1 F2 P	—	— Nessuna indicazione diametro standard	— S	O A	Vedi tabelle prestazioni See performance tables Siehe Leistungstabellen	80B5 80B14 ...	—	M1 M2 M3 M4 M5 M6	1 2 3 4	↓ PMP 63 1: 24.1 80 B5	
					C	No indications standard diameter				—	Look CT 18				PMP 71 -1:14.0 - T 56 A 4 B5
					N	Keine Angabe Standard-durchmesser				—	Look CT 18				
	B				Ø... Diametro foro opzionale	—				Look CT 18	PRP 90 P 1:125.0				
	D				Optional hollow shaft diameter	—				Look CT 18					PCP 112 - 1:44.7 - T 56 A 4 B5
DB	Optionaler Hohlwellen durchmesse	—	Look CT 18												
CD															
FD															
FDB															
QL															
L															

00 M - Macchina

M - Maschine

M - Getriebe



P

01 IV - Versione Entrata

IV - Input Version

IV - Antriebsausführung

M	R	C	
			63
			71
			90
			112
			125

Disponibile / available / verfügbar
Non disponibile / not available / nicht verfügbar

02 OV - Versione Uscita

OV - Output Version

OV - Abtriebsausführung

P	F
Riduttori e motoriduttori paralleli Parallel shaft gearboxes and motorgearboxes Flachgetriebe und -Flachtriebemotoren	Riduttori e motoriduttori pendolari Shaft mounted gearboxes and motorgearboxes Aufsteckgetriebe und Aufstecktriebemotoren



1.2 Designazione

1.2 Designation

1.2 Bezeichnung

03 SIZE - Grandezza

SIZE - Size

SIZE - Größe

	63	71	90	112	125
Stage	/2 and / 3			/2	

Senso di Rotazione
Rotation sense
Drehrichtung

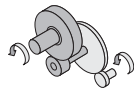

2 - Stage

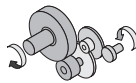

3 - Stage

04 OF - Flangia Uscita

OF - Output Flange

OF - Flansche am Abtrieb

—	F.	P
	Flangia Uscita F. / Output Flange F./ Flansche am Abtrieb F.	Flangia Uscita P / Output Flange P/ Flansche am Abtrieb P
Senza Flangia Without Flange Ohne Flansche		

05 OS - Estremità uscita

OS - Output shaft

OS - Wellenende - Abtrieb



— Nessuna indicazione = albero forato;
C = albero forato con calettatore
N = Sporgente Integrale
B = albero bisporgente integrale
D = Sporgente Scanalato
DB = Bisporgente integrale Scanalato
CD = Albero forato Scanalato
FD = Flangia brocciata
FDB = Flangia brocciata Bisporgente
QL = Quick Locking
L = Predisposizione "Quick Locking "

— No indication = shaft with keyway;
C = hollow shaft with shrink disk
N = Output shaft
B = Double integral output shaft
D = Splined output shaft
DB = Double splined shaft
CD = Splined hollow shaft
FD = Broached flange
FDB = Double broached flange
QL = Quick Locking
L = Adjustment "Quick Locking "

— Keine Angabe = Hohlwelle mit Paßfedernut
C = Hohlwelle mit Schrumpfscheibe
N = Holwelle mit Wellenende
B = Doppeltem Integralwelle
D = Abtriebswelle mit Keilende
DB = Doppelseitig verzahnte Welle
CD = Verzahnte Hohlwelle
FD = Geräumtem Flansch
FDB = Geraeumter Doppelflansch
QL = Quick Locking
L = Vorbereitung "Quick Locking "

i * FD - FDB - Contattare il ns. servizio tecnico / Contact our technical dept / Wenden Sie sich an unseren technischen Service

07 SD - Diametro albero

SD - Shaft diameter

SD - Durchmesser Abtriebswelle

— Nessuna indicazione = diametro standard;
diametro opzionale = vedi tabella.

— No indications = standard diameter;
optional diameter = see table.

— Keine Angabe = Standard-durchmesser
Optionaler durchmesser = siehe Tabelle.

					Standard Optional					
	Standard	Optional	Standard	Optional						
	—	∅...	—	∅...						
63	(∅ 30)	∅ 25 ∅ 28	(∅ 30)		(∅ 30 Standard)	(DIN 5482 35 x 31)	(DIN 5482 28 x 25)	(DIN 5482 35 x 31)		
71	(∅ 35)	∅ 30 ∅ 32	(∅ 35)		(∅ 35 Standard)	(DIN 5482 35 x 31)	(DIN 5482 35 x 31)	(DIN 5482 35 x 31)		
90	(∅ 40)	∅ 42 ∅ 45 ∅ 48	(∅ 40)	not available	(∅ 40 Standard)	(DIN 5482 40 x 36)	(DIN 5482 40 x 36)	(DIN 5482 40 x 36)		
112	(∅ 50)	∅ 55	(∅ 50)		(∅ 50 Standard)	(DIN 5482 58 x 53)	(DIN 5482 50 x 45)	(DIN 5482 58 x 53)		
125	(∅ 55)	∅ 50 ∅ 60	(∅ 55)		(∅ 55 Standard)	(DIN 5482 70 x 64)	(DIN 5482 55 x 50)	(DIN 5482 70 x 64)		



1.2 Designazione

1.2 Designation

1.2 Bezeichnung

07 SD - Diametro albero

SD - Shaft diameter

SD - Durchmesser Abtriebswelle

diametro = vedi tabella.

diameter = see table.

Durchmesser = siehe Tabelle.

Grandezza Size Größe		
71	$\varnothing 20 - \varnothing 25 - \varnothing 30$ $\varnothing 25 - \varnothing 30 - \varnothing 35 - \varnothing 38 - \varnothing 40 - \varnothing 42 - \varnothing 45 - \varnothing 48$ $\varnothing 30 - \varnothing 35 - \varnothing 40 - \varnothing 45 - \varnothing 50$ $\varnothing 35 - \varnothing 40 - \varnothing 45 - \varnothing 48 - \varnothing 50 - \varnothing 55$	Contattare nostro ufficio tecnico commerciale Please, contact our technical sales dept. Bitte setzen Sie sich mit unserer technischen Abteilung in Verbindung
80		
90		
112		
125		

08 MS - Posizione Albero

MS - Mounting Shaft

MS - Montageposition Welle

— Nessuna indicazione = lato destro (standard);
S = lato sinistro, montaggio dalla parte opposta
 (opzionale).

— No indication (standard) = on right side;
S = on left side, on the opposite.

— Keine Angabe (Standard) = rechts;
S = links.

Quick Locking		
Albero forato con calettatore Hollow shaft with shrink disc Holwelle mit Schrumpfscheibe		S
Sporgente Integrale Output shaft Holwelle mit Wellenende		S
Sporgente Scanalato Splined output shaft Abtriebswelle mit Keilende		S
Albero forato Scanalato Splined hollow shaft Verzahnte Holwelle		S
Flangia brocciata Broached flange Geräumtem Flansch		S

09 RSBSTOP - Senso di rotazione (valido solo se richiesto dispositivo antiretro)

RSBSTOP - Rotation sense (only necessary for solution with backstop device)

RSBSTOP - Drehrichtung (Nur bei Ausföhrungen mit Rücklaufsperr)

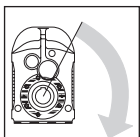

O = ORARIO (il riduttore può ruotare solo in senso orario visto dal lato destro come in figura);
A = ANTIORARIO.

O = CLOCKWISE (looking at the gearbox from the perspective shown below).
A = ANTICLOCKWISE.

O = im Uhrzeigersinn (bei Betrachtung des Getriebes aus der unten dargestellten Perspektive);
A = Gegen den Uhrzeigersinn.

10 IR - Rapporto di riduzione

IR - Reduction ratio

IR - Übersetzungsverhältnis

(Vedi prestazioni). Tutti i valori dei rapporti sono approssimati. Per applicazioni dove necessita il valore esatto consultare il ns. servizio tecnico.

(See ratings). Ratios are approximate values. If you need exact values for a specific application, please contact our Engineering.

(Siehe "Leistungen"). Bei allen Werten der Übersetzungen handelt es sich um approximative Wertangaben. Bei Applikationen, bei denen die exakte Wertangabe erforderlich ist, muss unser Technischer Kundendienst konsultiert werden.



1.2 Designazione

1.2 Designation

1.2 Bezeichnung

12 IS - Albero Entrata

IS - Input Shaft

IS - Antriebswelle

Nella tab. sono riportate le grandezze motore accoppiabili (IEC) unitamente alle dimensioni albero/flangia motore standard

In table the possible shaft/flange dimensions IEC standard are listed.

In Tabelle sind die möglichen Welle/Flansch-Abmessungen IEC-Standard aufgelistet.

Legenda:
11/140 (B5): combinazioni albero/flangia standard
 11/120 : combinazioni albero/flangia a richiesta

Key:
11/140 : standard shaft/flange combination
 11/120 : shaft/flange combinations upon request

Legende:
11/140 : Standardkombinationen Welle/Flansch
 11/120 : Sonderkombinationen Welle/Flansch

Possibili accoppiamenti con motori IEC - Possible couplings with IEC motors - Mögliche Verbindungen mit IEC-Motoren

		PM 	
		ir (Tutti / All / Alle)	
PMP 63/2 PMF 63/2	63	11/140 (B5)	
	71	14/160 (B5)	
	80	19/200 (B5) - 19/120 (B14)	19/160 - 19/140
	90	24/200 (B5) - 24/140 (B14)	24/160 - 24/120
PMP 63/3 PMF 63/3	100 112	28/250 (B5) - 28/160 (B14)	
	63	11/140 (B5)	
	71	14/160 (B5)	
PMP 71/2 PMF 71/2	80	19/200 (B5) - 19/120 (B14)	19/160 - 19/140
	71	14/160 (B5)	14/200 - 14/140 - 14/120
	80	19/200 (B5) - 19/120 (B14)	19/160 - 19/140
	90	24/200 (B5) - 24/140 (B14)	24/160 - 24/120
	100 112	28/250 (B5) - 28/160 (B14)	
PMP 71/3 PMF 71/3	63	11/140 (B5)	
	71	14/160 (B5)	14/200 - 14/140 - 14/120
	80	19/200 (B5) - 19/120 (B14)	19/160 - 19/140
	90	24/200 (B5) - 24/140 (B14)	24/160 - 24/120

		PM 	
		ir (Tutti / All / Alle)	
PMP 90/2 PMF 90/2	90	24/200 (B5)	24/300 - 24/250
	100 112	28/250 (B5)	28/200 - 28/300
	132	38/300 (B5) - 38/200 (B14)	38/250
	71	14/160 (B5)	14/200 - 14/140 - 14/120
PMP 90/3 PMF 90/3	80	19/200 (B5) - 19/120 (B14)	19/160 - 19/140
	90	24/200 (B5) - 24/140 (B14)	24/160 - 24/120
	100	28/250 (B5) - 28/160 (B14)	
	100 112	28/250 (B5)	28/350 - 28/300
PMP 112/2 PMF 112/2	132	38/300 (B5)	38/350 - 38/250
	160	42/350 (B5)	42/300 - 42/250
	80	19/200 (B5)	
PMP 112/3 PMF 112/3	90	24/200 (B5)	
	100 112	28/250 (B5)	
	200 ¹	55/400 (B5)	
PMP 125/2	180 ¹	48/350 (B5)	
	160 ¹	42/350 (B5)	
	132	38/300 (B5) - 38/200 (B14)	38/250
	112	28/250 (B5)	28/200 - 28/300
	100	28/250 (B5)	28/200 - 28/300
	100	28/250 (B5)	28/200 - 28/300

¹ Da PAM 160 a PAM 200 forniti con giunto tipo Rotex (per prescrizione di montaggio vedere sezione A paragrafo "installazione" - 1.12)

¹ PAM 160 through PAM 200 come with Rotex coupling (for mounting directions, see section A, paragraph "Installation" - 1.12)

¹ Ab PAM 160 bis PAM 200 werden sie mit Kupplung Typ Rotex geliefert (hinsichtlich Montagegenauigkeit siehe Abschnitt A im Paragraph „Einbau“ - 1.12).



Posizione morsetteria - Vedere - 15 - PMT - Pagina E6 Terminal board position - Look - 15 - PMT - Page E6 Lage des Klemmenkastens - Siehe - 15 - PMT - Auf Seite E6

Designazione motore elettrico Se è richiesto un motoriduttore completo di motore è necessario riportare la designazione di quest'ultimo. A tale proposito consultare il ns. catalogo dei motori elettrici Electronic Line.	Electric motor designation For applications requiring a gearmotor, motor designation must be specified. To this end, please refer to our Electronic Line electric motor catalogue.	Bezeichnung des Elektromotors Wird ein Getriebemotor komplett mit Elektromotor angefordert, müssen dessen Daten angegeben werden. Diesbezüglich verweisen wir auf unseren Katalog der Elektromotoren "Electronic Line".
---	---	--

12 IS - Albero Entrata

IS - Input Shaft

IS - Antriebswelle

— Nessuna indicazione = diametro standard;

— No indications = standard diameter;

— Keine Angabe = Standard-durchmesser

PR 	63	71	90	112	125
	(Ø 16)	(Ø 16)	(Ø 19)	(Ø 24)	(Ø 28)



1.2 Designazione

1.2 Designation

1.2 Bezeichnung

13 MP - Posizioni di montaggio

[M2, M3, M4, M5, M6] Posizioni di montaggio con indicazione dei tappi di livello, carico e scarico; se non specificato si considera standard la posizione **M1** (vedi par. 1.4)

MP - Mounting positions

[M2, M3, M4, M5, M6] Mounting position with indication of breather level and drain plugs; if not specified, standard position is **M1** (see par. 1.4).

MP - Einbaulagen

Montageposition **[M2, M3, M4, M5, M6]** mit Angabe von . Entlüftung, Schaugläsern und Ablasschraube. Wenn nicht näher spezifiziert, wird die Standard - position **M1** zugrunde gelegt (s. Abschnitt 1.4).

14 OPT-ACC. - Opzioni

OPT-ACC. - Options

OPT-ACC. - Optionen

vedi par. 1.9 see pa. 1.9 s. Abschnitt 1.9	ACC1	AL	Alberi lenti - AL	Output shafts - AL	Abtriebswellen - AL
		PROT.	Coperchio di protezione	Protection cover	Schutzeinrichtungendeckel
		FF	FF - Kit	FF - Kit	FF - Kit
		RR	Kit rosetta di montaggio	Mounting washer kit	Kit Montagescheibe
	ACC3	AV	ANTIVIBRANTE VKL	RUBBER BUFFER VKL	GUMMIHÜLSE VKL

vedi Sezione A-1.12 see Section A-1.12 s. Abschnitt A-1.12	OPT.	OPT	Materiale degli anelli di tenuta	Materials of Seals	Dichtungsstoffe
		OPT1	Stato forniture olio	Scope of the supply - Options - OIL	Optionen - Lieferzustand - Optionen - Öl
		OPT2	Verniciatura	Painting and surface protection	Lackierung und Oberflächenschutz

15 PMT - Posizioni della Morsettieria

[2, 3, 4] Posizione della morsettieria del motore se diversa da quella standard (1).

PMT - Position Terminal Box

[2, 3, 4] Position of the motor terminal box if different from the standard one (1).

PMT - Montagposition Klemmenkasten

Montageposition Klemmenkasten **[2, 3, 4]**, wenn abweichend von Standardposition **[1]** (für Motorgetriebe).

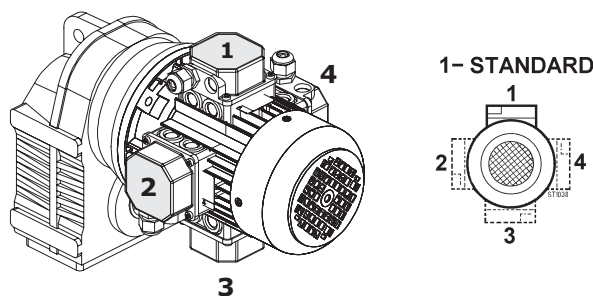



1.4 Lubrificazione

1.4 Lubrication

1.4 Schmierung



Posizioni di montaggio
Mounting positions
Montagepositionen

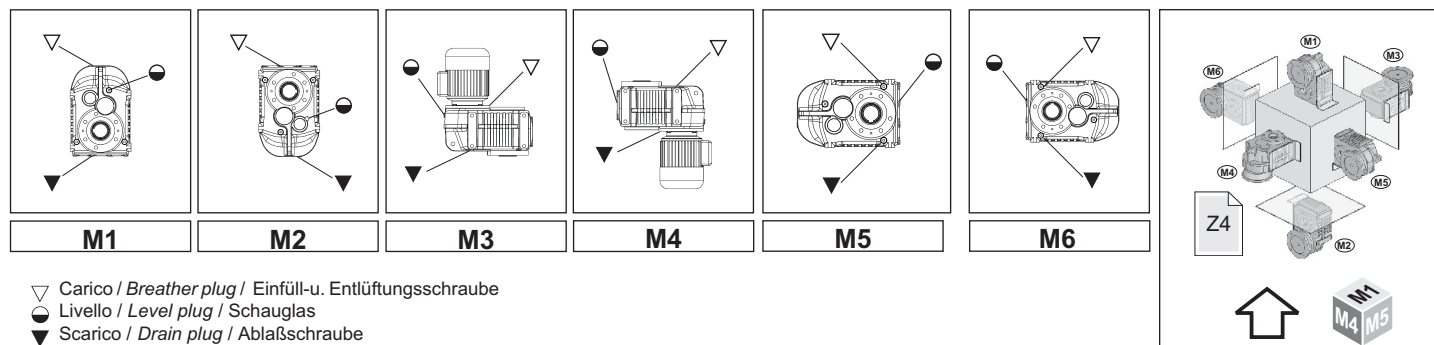

- ▽ Carico / Breather plug / Einfüll-u. Entlüftungsschraube
- Livello / Level plug / Schauglas
- ▼ Scarico / Drain plug / Ablasschraube

Posizioni di montaggio - Mounting positions - Montagepositionen			
PR PM PC		Posizioni Positions Positionen	Prescrizioni da indicare in fase d'ordine Ordering requirements Anforderungen bei der Bestellung
	63	M1-M2 M3-M4 M5-M6	Necessaria Necessary Erforderlich
	71		
	90		
	112		
125			

TARGHETTA - RIDUTTORE

NON NECESSARIA

Indicata sempre nella targhetta del riduttore la posizione di montaggio "M1".

NECESSARIA

La posizione richiesta è indicata nella targhetta del riduttore

Identification Plate - Gearbox

NOT NECESSARY

The mounting position is always indicated on the nameplate "M1".

NECESSARY

The indication it on the label of the gearbox

Typeschild - Getriebe

NICHT ERFORDERLICH

Die Einbaulage ist immer auf dem Typenschild angegeben "M1".

ERFORDERLICH

Findet man die angefragte Position auf dem Typenschild des Getriebe

Lub	Quantità di lubrificante - Lubricant Quantity - Schmiermittelmenge - [Kg]							OPT1	Tappi-Plug-Stopfen		
		M1	M2	M3	M4	M5	M6		N°	Diameter	Type
PR PM PC	63	1.250	0.900	1.300	1.150	0.900	0.900	INOIL_STD	1	1/4"	▼
	71	2.100	1.750	2.300	2.000	1.600	1.600		1	1/4"	▼
	90	3.300	2.800	3.800	3.700	2.650	2.650	OUTOIL	4	1/4"	▼
	112	7.300	7.100	8.000	7.000	6.000	6.000		4	1/4"	○
	125	8.500	7.500	8.700	8.500	6.000	6.000		5	1/8"	●

Quantità indicative; durante il riempimento attenersi alla spia di livello.

Indicative quantities, check the oil sight glass during filling.

Richtungsweisende Mengen, bei der Auffüllung auf das Füllstand-Kontrollfenster Bezug nehmen.

Attenzione !: Il tappo di sfiato è allegato solo nei riduttori che hanno più di un tappo olio

Warning!: A breather plug is supplied only with worm gearboxes that have more than one oil plug

Achtung!: Der Entlüftungsstopfen ist lediglich bei den Getrieben vorhanden, die über mehr als einen Öfüllstopfen verfügen

Nota: Se in fase d'ordine la posizione di montaggio è omessa, il riduttore verrà fornito con i tappi predisposti per la posizione M1.

Note: If the mounting position is not specified in the order, the worm gearbox supplied will have plugs pre-arranged for position M1.

Anmerkung: Sollte in der Auftragsphase die Einbaulage nicht angegeben werden, wird das Getriebe mit Stopfen für die Einbaulage M1.

Eventuali forniture con predisposizioni tappi diverse da quella indicata in tabella, dovranno essere concordate.

The supply of gearboxes with different plug pre-arrangements has to be agreed with the manufacturer.

Lieferungen, die eine Auslegung hinsichtlich der Stopfen aufweisen, die von den Angaben in der Tabelle abweichen, müssen vorab vereinbart werden..



1.5 Carichi radiali e assiali

Quando la trasmissione del moto avviene tramite meccanismi che generano carichi radiali sull'estremità dell'albero, è necessario verificare che i valori risultanti non eccedono quelli indicati nelle tabelle.

Nella Tab. 4.3 sono riportati i valori dei carichi radiali ammissibili per l'albero veloce (F_{r1}). Come carico assiale ammissibile contemporaneo si ha:

$$F_{a1} = 0.2 \times F_{r1}$$

In Tab. 4.4 sono riportati i valori dei carichi radiali ammissibili per l'albero lento (F_{r2}). Come carico assiale ammissibile contemporaneo si ha:

$$F_{a2} = 0.2 \times F_{r2}$$

Tab. 4.3

n_1 [min ⁻¹]	F_{r1} [N]									
	PR.									
	63/2	63/3	71/2	71/3	90/2	90/3	112/2	112/3	125/2	125/3
2800	200	550	600	600	600	1300	800	1400	1000	1000
1400	400	700	900	800	700	1500	1400	1800	1200	1200
900	400	800	1100	1000	800	1600	1500	2100	1300	1300
500	400	950	1300	1200	900	1800	1800	2600	1500	1500

Tab. 4.4

n_2 [min ⁻¹]	F_{r2} [N]				
	PM. - PR. - PC.				
	63	71	90	112	125
1100	—	3000	6500	—	—
950	1400	3050	7000	7600	—
775	1450	3100	7200	7900	—
625	1500	3230	7600	8300	—
500	1580	3340	7900	8800	10000
400	1660	3450	8300	9200	10500
320	1720	3550	8900	9800	11200
260	1750	3600	9000	10400	12000
200	1800	4100	9000	10800	12500
160	1950	4300	9000	11400	13000
125	2200	4600	9000	12000	14000
90	2400	4900	9000	13000	16000
60	2600	5000	9300	13800	18000
40	2800	5000	10000	15300	20000
25	3100	6000	11200	16500	20000
16	3800	6600	11500	17000	20000
10	4500	6600	11500	17400	20000

I carichi radiali indicati nelle tabelle si intendono applicati a metà della sporgenza dell'albero lento standard (vedi fig. 8.14) e sono riferiti ai riduttori operanti con fattore di servizio 1. Valori intermedi relativi a velocità non riportate possono essere ottenuti per interpolazione considerando però che F_{r1} a 500 min⁻¹ e F_{r2} a 5 min⁻¹ rappresentano i carichi massimi consentiti. Per i carichi non agenti sulla mezzeria dell'albero lento o veloce si ha:

- a 0.3 della sporgenza:
 $F_{rx} = 1.25 \times F_{r1-2}$
- a 0.8 dalla sporgenza:
 $F_{rx} = 0.8 \times F_{r1-2}$

1.5 Axial and overhung load

Should transmission movement determine radial loads on the angular shaft end, it is necessary to make sure that resulting values do not exceed the ones indicated in the tables.

In Table 4.3 permissible radial load for input shaft are listed (F_{r1}). Contemporary permissible axial load is given by the following formula:

$$F_{a1} = 0.2 \times F_{r1}$$

In Table 4.4 permissible radial loads for output shaft are listed (F_{r2}). Permissible axial load is given by the following formula:

$$F_{a2} = 0.2 \times F_{r2}$$

1.5 Radiale und axiale Belastungen

Wird das Wellenende auch durch Radialkräfte belastet, so muß sichergestellt werden, daß die resultierenden Werte die in der Tabelle angegebenen nicht überschreiten.

In Tabelle 4.3 sind die Werte der zulässigen Radialbelastungen für die Antriebswelle (F_{r1}) angegeben. Die Axialbelastung beträgt dann:

$$F_{a1} = 0.2 \times F_{r1}$$

In Tabelle 4.4 sind die Werte der zulässigen Radialbelastungen für die Abtriebswelle (F_{r2}) angegeben. Als zulässige Axialbelastung gilt:

$$F_{a2} = 0.2 \times F_{r2}$$

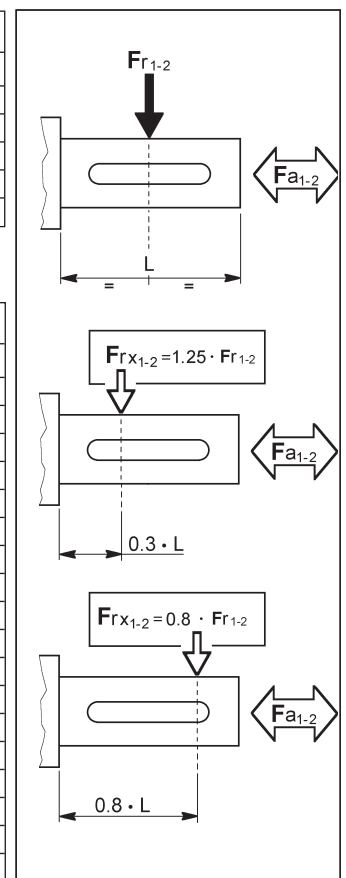

The radial loads shown in the tables are applied on the middle of standard shaft extensions (see fig.8.14). Base of these values is a service factor 1.

Values for speeds that are not listed can be obtained through interpolation but it must be considered that F_{r1} at 500 min⁻¹ and F_{r2} at 5 min⁻¹ represent the maximum allowable loads.

For radial loads which are not applied on the middle of the shafts, the following values can be calculated:

- at 0.3 from extension:
 $F_{rx} = 1.25 \times F_{r1-2}$
- at 0.8 from extension:
 $F_{rx} = 0.8 \times F_{r1-2}$

Bei den in der Tabelle angegebenen Radialbelastungen wird eine Kräfteinwirkung auf die Mitte der Standardwelle (s. A.8.14) angenommen; außerdem wird ein Betriebsfaktor 1 zugrunde gelegt. Zwischenwerte für nicht aufgeführte Drehzahlen können durch Interpolation ermittelt werden. Hierbei ist jedoch zu berücksichtigen, daß F_{r1} bei 500 min⁻¹ und für F_{r2max} bei 5 min⁻¹ die maximal zulässigen Belastungen repräsentieren.

Ist die Einwirkung der Radialkraft nicht in der Mitte der Welle, so können die zulässigen Radiallasten folgendermaßen ermittelt werden:

- 0.3 vom Wellenabsatz entfernt:
 $F_{rx} = 1.25 \times F_{r1-2}$
- 0.8 vom Wellenabsatz entfernt:
 $F_{rx} = 0.8 \times F_{r1-2}$



1.6 Prestazioni riduttori PR

1.6 PR gearboxes performances

1.6 Leistungen der PR-Getriebe

PR 63/2



9.0

ir	n ₁ = 2800 min ⁻¹				n ₁ = 1400 min ⁻¹				n ₁ = 900 min ⁻¹				n ₁ = 500 min ⁻¹				IEC
	n ₂	T _{2M}	P	RD	n ₂	T _{2M}	P	RD	n ₂	T _{2M}	P	RD	n ₂	T _{2M}	P	RD	
	min ⁻¹	Nm	kW	%	min ⁻¹	Nm	kW	%	min ⁻¹	Nm	kW	%	min ⁻¹	Nm	kW	%	
3.0	935.6	77	7.9	95	467.8	80	4.1	95	300.7	85	2.8	95	167.1	88	1.6	95	112 B5 112 B14
3.9	719.9	90	7.1	95	360.0	110	4.4	95	231.4	115	2.9	95	128.6	120	1.7	95	
4.3	645.0	95	6.8	95	322.5	130	4.6	95	207.3	135	3.1	95	115.2	140	1.8	95	
5.0	557.0	110	6.8	95	278.5	140	4.3	95	179.0	150	3.0	95	99.5	155	1.7	95	
5.6	499.0	125	6.9	95	249.5	160	4.4	95	160.4	170	3.0	95	89.1	180	1.8	95	
6.2	452.2	130	6.5	95	226.1	160	4.0	95	145.3	175	2.8	95	80.7	180	1.6	95	
6.5	431.2	135	6.4	95	215.6	170	4.0	95	138.6	185	2.8	95	77.0	195	1.7	95	
7.4	379.1	140	5.9	95	189.6	180	3.8	95	121.9	190	2.6	95	67.7	200	1.5	95	
8.0	347.9	150	5.8	95	174.0	200	3.8	95	111.8	215	2.7	95	62.1	230	1.6	95	
9.0	311.7	165	5.7	95	155.9	210	3.6	95	100.2	230	2.5	95	55.7	250	1.5	95	
10.4	269.4	180	5.3	95	134.7	220	3.3	95	86.6	240	2.3	95	48.1	255	1.4	95	
11.8	236.9	190	5.0	95	118.4	235	3.1	95	76.1	255	2.1	95	42.3	255	1.2	95	
13.5	206.9	205	4.7	95	103.4	250	2.9	95	66.5	255	1.9	95	36.9	255	1.0	95	
14.4	194.8	190	4.1	95	97.4	220	2.4	95	62.5	230	1.6	95	34.8	240	0.9	95	
16.9	166.1	230	4.2	95	83.0	250	2.3	95	53.4	255	1.5	95	29.7	255	0.8	95	
19.8	141.3	230	3.6	95	70.7	250	1.9	95	45.4	255	1.3	95	25.2	255	0.7	95	
20.5	136.6	210	3.2	95	68.3	230	1.7	95	43.9	240	1.2	95	24.4	250	0.7	95	
24.1	116.2	210	2.7	95	58.1	230	1.5	95	37.3	245	1.0	95	20.7	250	0.6	95	
26.1	107.3	220	2.6	95	53.6	240	1.4	95	34.5	250	1.0	95	19.2	255	0.5	95	
31.7	88.2	220	2.1	95	44.1	240	1.2	95	28.4	250	0.8	95	15.8	250	0.4	95	
36.6	76.6	225	1.9	95	38.3	250	1.1	95	24.6	250	0.7	95	13.7	250	0.4	95	
40.5	69.2	220	1.7	95	34.6	240	0.9	95	22.2	240	0.6	95	12.3	240	0.3	95	
45.2	62.0	220	1.5	95	31.0	240	0.8	95	19.9	240	0.5	95	11.1	240	0.3	95	

PR 63/3



9.0

ir	n ₁ = 2800 min ⁻¹				n ₁ = 1400 min ⁻¹				n ₁ = 900 min ⁻¹				n ₁ = 500 min ⁻¹				IEC
	n ₂	T _{2M}	P	RD	n ₂	T _{2M}	P	RD	n ₂	T _{2M}	P	RD	n ₂	T _{2M}	P	RD	
	min ⁻¹	Nm	kW	%	min ⁻¹	Nm	kW	%	min ⁻¹	Nm	kW	%	min ⁻¹	Nm	kW	%	
43.4	64.6	220	1.6	93	32.3	250	0.9	93	20.7	250	0.6	93	11.5	250	0.3	93	80 B5 80 B14
47.0	59.6	200	1.3	93	29.8	250	0.8	93	19.2	255	0.6	93	10.6	255	0.3	93	
53.3	52.5	220	1.3	93	26.3	250	0.7	93	16.9	255	0.5	93	9.4	255	0.3	93	
57.2	48.9	230	1.3	93	24.5	250	0.7	93	15.7	255	0.5	93	8.7	255	0.3	93	
61.8	45.3	230	1.2	93	22.7	250	0.6	93	14.6	255	0.4	93	8.1	255	0.2	93	
69.6	40.2	240	1.1	93	20.1	250	0.6	93	12.9	250	0.4	93	7.2	250	0.2	93	
75.4	37.1	240	1.0	93	18.6	250	0.5	93	11.9	255	0.3	93	6.6	255	0.2	93	
81.4	34.4	240	0.9	93	17.2	250	0.5	93	11.1	255	0.3	93	6.1	255	0.2	93	
88.4	31.7	240	0.9	93	15.8	250	0.4	93	10.2	250	0.3	93	5.7	250	0.2	93	
98.9	28.3	240	0.8	93	14.2	250	0.4	93	9.1	250	0.3	93	5.1	250	0.1	93	
114.4	24.5	240	0.7	93	12.2	250	0.3	93	7.9	255	0.2	93	4.4	260	0.1	93	
135.4	20.7	240	0.6	93	10.3	250	0.3	93	6.6	255	0.2	93	3.7	260	0.1	93	
149.1	18.8	240	0.5	93	9.4	250	0.3	93	6.0	255	0.2	93	3.4	260	0.1	93	
164.7	17.0	240	0.5	93	8.5	250	0.2	93	5.5	250	0.2	93	3.0	260	0.1	93	
181.3	15.4	240	0.4	93	7.7	250	0.2	93	5.0	250	0.1	93	2.8	260	0.1	93	
216.9	12.9	240	0.3	93	6.5	250	0.2	93	4.2	255	0.1	93	2.3	260	0.1	93	

P _{tN} [kW]	tutti i rapporti all ratios alle Untersetzungen
	5.6

N.B.
Per i riduttori evidenziati dal doppio bordo nella colonna delle potenze è necessario verificare lo scambio termico del riduttore (come indicato nel par. A-1.5). Per maggiori informazioni contattare l'ufficio tecnico STM.

NOTE.
Pay attention please to the frame around the input power value: for this gearboxes it's important to check the thermal capacity (comp. par. A-1.5). For details please contact our technical office.

HINWEIS.
Sind in den Tabellen Nennleistungen eingerahmt, so ist die thermische Leistungsgrenze der Getriebe zu beachten (s. par.A-1.5). Für weitere Informationen wenden Sie sich bitte an unser technisches Büro.

N.B.
I pesi riportati sono indicativi e possono variare in funzione della versione del riduttore.

NOTE.
Listed weights are for reference only and can vary according to the gearbox version.

HINWEIS.
Die angegebenen Gewichtsmaße sind Richtwerte und können je nach Getriebeversion variieren.



1.6 Prestazioni riduttori PR

1.6 PR gearboxes performances

1.6 Leistungen der PR-Getriebe

PR 71/2



14.0

ir	n ₁ = 2800 min ⁻¹				n ₁ = 1400 min ⁻¹				n ₁ = 900 min ⁻¹				n ₁ = 500 min ⁻¹				IEC
	n ₂ min ⁻¹	T _{2M} Nm	P kW	RD %	n ₂ min ⁻¹	T _{2M} Nm	P kW	RD %	n ₂ min ⁻¹	T _{2M} Nm	P kW	RD %	n ₂ min ⁻¹	T _{2M} Nm	P kW	RD %	
2.6	1078.5	120	14.3	95	539.3	130	7.7	95	346.7	130	5.0	95	192.6	130	2.8	95	112 B5 112 B14
3.2	880.4	140	13.6	95	440.2	150	7.3	95	283.0	150	4.7	95	157.2	150	2.6	95	
3.8	745.8	160	13.2	95	372.9	175	7.2	95	239.7	180	4.8	95	133.2	180	2.6	95	
4.3	650.3	180	12.9	95	325.2	200	7.2	95	209.0	210	4.8	95	116.1	210	2.7	95	
5.3	530.9	180	10.5	95	265.4	210	6.1	95	170.6	230	4.3	95	94.8	230	2.4	95	
6.2	449.7	230	11.4	95	224.8	260	6.4	95	144.5	300	4.8	95	80.3	300	2.7	95	
7.1	395.3	270	11.8	95	197.6	300	6.5	95	127.1	330	4.6	95	70.6	330	2.6	95	
8.7	322.7	280	10.0	95	161.3	310	5.5	95	103.7	350	4.0	95	57.6	350	2.2	95	
10.2	273.3	370	11.1	95	136.7	420	6.3	95	87.9	470	4.6	95	48.8	470	2.5	95	
11.6	242.0	380	10.1	95	121.0	430	5.7	95	77.8	480	4.1	95	43.2	480	2.3	95	
12.3	228.2	280	7.0	95	114.1	300	3.8	95	73.3	310	2.5	95	40.7	310	1.4	95	
14.0	199.5	400	8.8	95	99.8	450	4.9	95	64.1	480	3.4	95	35.6	480	1.9	95	
16.1	173.9	420	8.0	95	86.9	460	4.4	95	55.9	480	3.0	95	31.0	480	1.6	95	
17.3	161.7	420	7.5	95	80.9	460	4.1	95	52.0	480	2.8	95	28.9	480	1.5	95	
18.7	150.0	420	6.9	95	75.0	460	3.8	95	48.2	480	2.6	95	26.8	480	1.4	95	
20.2	138.7	420	6.4	95	69.3	460	3.5	95	44.6	480	2.4	95	24.8	480	1.3	95	
21.9	127.8	420	5.9	95	63.9	460	3.2	95	41.1	480	2.2	95	22.8	480	1.2	95	
25.3	110.9	360	4.4	95	55.4	410	2.5	95	35.6	410	1.6	95	19.8	410	0.9	95	
28.8	97.2	410	4.4	95	48.6	460	2.5	95	31.2	460	1.6	95	17.4	460	0.9	95	
33.1	84.7	370	3.5	95	42.4	410	1.9	95	27.2	410	1.2	95	15.1	410	0.7	95	
37.3	75.1	365	3.0	95	37.5	410	1.7	95	24.1	410	1.1	95	13.4	420	0.6	95	
44.7	62.6	400	2.8	95	31.3	460	1.6	95	20.1	460	1.0	95	11.2	480	0.6	95	
50.5	55.5	400	2.4	95	27.7	460	1.4	95	17.8	460	0.9	95	9.9	480	0.5	95	

PR 71/3



14.0

ir	n ₁ = 2800 min ⁻¹				n ₁ = 1400 min ⁻¹				n ₁ = 900 min ⁻¹				n ₁ = 500 min ⁻¹				IEC
	n ₂ min ⁻¹	T _{2M} Nm	P kW	RD %	n ₂ min ⁻¹	T _{2M} Nm	P kW	RD %	n ₂ min ⁻¹	T _{2M} Nm	P kW	RD %	n ₂ min ⁻¹	T _{2M} Nm	P kW	RD %	
39.5	70.8	420	3.3	93	35.4	460	1.8	93	22.8	470	1.2	93	12.6	480	0.7	93	90 B5 90 B14
53.5	52.3	420	2.5	93	26.2	460	1.4	93	16.8	460	0.9	93	9.3	480	0.5	93	
60.8	46.0	420	2.2	93	23.0	460	1.2	93	14.8	460	0.8	93	8.2	480	0.4	93	
64.2	43.6	420	2.1	93	21.8	460	1.1	93	14.0	470	0.7	93	7.8	480	0.4	93	
75.4	37.2	420	1.8	93	18.6	460	1.0	93	11.9	470	0.6	93	6.6	480	0.4	93	
86.8	32.3	420	1.5	93	16.1	460	0.8	93	10.4	470	0.5	93	5.8	480	0.3	93	
91.5	30.6	420	1.4	93	15.3	460	0.8	93	9.8	470	0.5	93	5.5	480	0.3	93	
99.3	28.2	420	1.3	93	14.1	460	0.7	93	9.1	470	0.5	93	5.0	480	0.3	93	
107.5	26.0	420	1.2	93	13.0	460	0.7	93	8.4	470	0.4	93	4.6	480	0.3	93	
123.8	22.6	420	1.1	93	11.3	460	0.6	93	7.3	480	0.4	93	4.0	520	0.2	93	
134.3	20.9	420	1.0	93	10.4	460	0.5	93	6.7	490	0.4	93	3.7	520	0.2	93	
154.8	18.1	420	0.9	93	9.0	460	0.5	93	5.8	500	0.3	93	3.2	520	0.2	93	
163.2	17.2	420	0.8	93	8.6	460	0.4	93	5.5	470	0.3	93	3.1	480	0.2	93	
191.6	14.6	450	0.7	93	7.3	490	0.4	93	4.7	520	0.3	93	2.6	540	0.2	93	
220.8	12.7	450	0.6	93	6.3	500	0.4	93	4.1	520	0.2	93	2.3	540	0.1	93	

Pt _N [kW]	tutti i rapporti all ratios alle Untersetzungen
	7.5

N.B.
Per i riduttori evidenziati dal doppio bordo nella colonna delle potenze è necessario verificare lo scambio termico del riduttore (come indicato nel par. A-1.5). Per maggiori informazioni contattare l'ufficio tecnico STM.

NOTE.
Pay attention please to the frame around the input power value: for this gearboxes it's important to check the thermal capacity (comp. par. A-1.5). For details please contact our technical office.

HINWEIS.
Sind in den Tabellen Nennleistungen eingerahmt, so ist die thermische Leistungsgrenze der Getriebe zu beachten (s. par.A-1.5). Für weitere Informationen wenden Sie sich bitte an unser technisches Büro.

N.B.
I pesi riportati sono indicativi e possono variare in funzione della versione del riduttore.

NOTE.
Listed weights are for reference only and can vary according to the gearbox version.

HINWEIS.
Die angegebenen Gewichtsmaße sind Richtwerte und können je nach Getriebeversion variieren.



1.6 Prestazioni riduttori PR

1.6 PR gearboxes performances

1.6 Leistungen der PR-Getriebe

PR 90/2



30

ir	n ₁ = 2800 min ⁻¹				n ₁ = 1400 min ⁻¹				n ₁ = 900 min ⁻¹				n ₁ = 500 min ⁻¹				IEC
	n ₂ min ⁻¹	T _{2M} Nm	P kW	RD %	n ₂ min ⁻¹	T _{2M} Nm	P kW	RD %	n ₂ min ⁻¹	T _{2M} Nm	P kW	RD %	n ₂ min ⁻¹	T _{2M} Nm	P kW	RD %	
2.7	1025.6	270	30.5	95	512.8	330	18.7	95	329.7	330	12.0	95	183.2	330	6.7	95	132 B5 132 B14
4.2	662.1	390	28.5	95	331.0	480	17.5	95	212.8	480	11.3	95	118.2	480	6.3	95	
5.3	528.9	430	25.1	95	264.5	530	15.4	95	170.0	530	9.9	95	94.5	530	5.5	95	
5.9	470.7	450	23.3	95	235.3	560	14.5	95	151.3	560	9.3	95	84.1	560	5.2	95	
6.7	417.1	480	22.1	95	208.6	600	13.8	95	134.1	600	8.9	95	74.5	600	4.9	95	
7.8	361.0	520	20.7	95	180.5	650	12.9	95	116.0	700	9.0	95	64.5	720	5.1	95	
8.7	321.8	460	16.3	95	160.9	560	9.9	95	103.4	560	6.4	95	57.5	560	3.5	95	
9.3	300.2	460	15.2	95	150.1	560	9.3	95	96.5	560	6.0	95	53.6	560	3.3	95	
9.7	288.4	660	21.0	95	144.2	820	13.0	95	92.7	880	9.0	95	51.5	900	5.1	95	
10.9	256.7	700	19.8	95	128.3	860	12.2	95	82.5	920	8.4	95	45.8	920	4.6	95	
12.3	227.4	740	18.6	95	113.7	910	11.4	95	73.1	920	7.4	95	40.6	940	4.2	95	
14.0	200.5	740	16.4	95	100.2	910	10.1	95	64.4	920	6.5	95	35.8	940	3.7	95	
16.0	175.5	740	14.3	95	87.7	910	8.8	95	56.4	920	5.7	95	31.3	940	3.2	95	
17.1	163.7	740	13.4	95	81.8	910	8.2	95	52.6	920	5.3	95	29.2	940	3.0	95	
19.8	141.3	740	11.5	95	70.7	910	7.1	95	45.4	920	4.6	95	25.2	940	2.6	95	
21.4	130.7	740	10.7	95	65.4	910	6.6	95	42.0	920	4.3	95	23.3	940	2.4	95	
25.0	112.2	740	9.1	95	56.1	910	5.6	95	36.1	920	3.7	95	20.0	940	2.1	95	
27.7	101.0	740	8.2	95	50.5	910	5.1	95	32.5	920	3.3	95	18.0	940	1.9	95	
30.5	91.7	740	7.5	95	45.9	910	4.6	95	29.5	920	3.0	95	16.4	940	1.7	95	
35.0	80.0	700	6.2	95	40.0	850	3.7	95	25.7	890	2.5	95	14.3	920	1.4	95	
40.4	69.3	585	4.5	95	34.7	720	2.8	95	22.3	760	1.9	95	12.4	820	1.1	95	
44.1	63.5	700	4.9	95	31.8	860	3.0	95	20.4	950	2.1	95	11.3	1000	1.4	95	
50.9	55.0	700	4.2	95	27.5	860	2.6	95	17.7	950	1.9	95	9.8	1000	1.1	95	



PR 90/3



30

ir	n ₁ = 2800 min ⁻¹				n ₁ = 1400 min ⁻¹				n ₁ = 900 min ⁻¹				n ₁ = 500 min ⁻¹				IEC
	n ₂ min ⁻¹	T _{2M} Nm	P kW	RD %	n ₂ min ⁻¹	T _{2M} Nm	P kW	RD %	n ₂ min ⁻¹	T _{2M} Nm	P kW	RD %	n ₂ min ⁻¹	T _{2M} Nm	P kW	RD %	
38.7	72.3	700	5.7	93	36.2	910	3.7	93	23.2	945	2.5	93	12.9	945	1.4	93	100 B5 100 B14
43.7	64.0	750	5.4	93	32.0	910	3.3	93	20.6	945	2.2	93	11.4	945	1.2	93	
48.8	57.4	750	4.8	93	28.7	910	2.9	93	18.4	945	2.0	93	10.2	945	1.1	93	
55.2	50.7	720	4.1	93	25.4	910	2.6	93	16.3	945	1.7	93	9.1	945	1.0	93	
62.3	44.9	750	3.8	93	22.5	910	2.3	93	14.4	945	1.5	93	8.0	945	0.9	93	
70.6	39.7	800	3.6	93	19.8	910	2.0	93	12.8	945	1.4	93	7.1	945	0.8	93	
76.3	36.7	800	3.3	93	18.3	910	1.9	93	11.8	945	1.3	93	6.6	945	0.7	93	
82.8	33.8	800	3.0	93	16.9	910	1.7	93	10.9	945	1.2	93	6.0	945	0.6	93	
93.3	30.0	800	2.7	93	15.0	910	1.5	93	9.6	945	1.0	93	5.4	945	0.6	93	
100.6	27.8	800	2.5	93	13.9	910	1.4	93	8.9	945	1.0	93	5.0	945	0.5	93	
108.9	25.7	910	2.6	93	12.9	910	1.3	93	8.3	945	0.9	93	4.6	945	0.5	93	
125.0	22.4	910	2.3	93	11.2	910	1.1	93	7.2	945	0.8	93	4.0	945	0.4	93	
141.0	19.9	910	2.0	93	9.9	910	1.0	93	6.4	945	0.7	93	3.5	945	0.4	93	
155.2	18.0	910	1.8	93	9.0	910	0.9	93	5.8	945	0.6	93	3.2	945	0.3	93	
178.1	15.7	910	1.6	93	7.9	910	0.8	93	5.1	945	0.5	93	2.8	945	0.3	93	
201.0	13.9	910	1.4	93	7.0	910	0.7	93	4.5	945	0.5	93	2.5	945	0.3	93	
224.4	12.5	910	1.3	93	6.2	910	0.6	93	4.0	945	0.4	93	2.2	945	0.2	93	
253.2	11.1	910	1.1	93	5.5	910	0.6	93	3.6	945	0.4	93	2.0	945	0.2	93	

Pt _N [kW]	tutti i rapporti all ratios alle Untersetzungen
	10.5

N.B.
Per i riduttori evidenziati dal doppio bordo nella colonna delle potenze è necessario verificare lo scambio termico del riduttore (come indicato nel par. A-1.5). Per maggiori informazioni contattare l'ufficio tecnico STM.

NOTE.
Pay attention please to the frame around the input power value: for this gearboxes it's important to check the thermal capacity (comp. par. A-1.5). For details please contact our technical office.

HINWEIS.
Sind in den Tabellen Nennleistungen eingerahmt, so ist die thermische Leistungsgrenze der Getriebe zu beachten (s. par.A-1.5). Für weitere Informationen wenden Sie sich bitte an unser technisches Büro.

N.B.
I pesi riportati sono indicativi e possono variare in funzione della versione del riduttore.

NOTE.
Listed weights are for reference only and can vary according to the gearbox version.

HINWEIS.
Die angegebenen Gewichtsmaße sind Richtwerte und können je nach Getriebeversion variieren.



1.6 Prestazioni riduttori PR

1.6 PR gearboxes performances

1.6 Leistungen der PR-Getriebe

PR 112/2



ir	n ₁ = 2800 min ⁻¹				n ₁ = 1400 min ⁻¹				n ₁ = 900 min ⁻¹				n ₁ = 500 min ⁻¹				IEC
	n ₂ min ⁻¹	T _{2M} Nm	P kW	RD %	n ₂ min ⁻¹	T _{2M} Nm	P kW	RD %	n ₂ min ⁻¹	T _{2M} Nm	P kW	RD %	n ₂ min ⁻¹	T _{2M} Nm	P kW	RD %	
2.9	967.0	480	51.2	95	483.5	600	32.0	95	310.8	650	22.3	95	172.7	650	12.4	95	160 B5
3.4	831.9	520	47.7	95	416.0	640	29.3	95	267.4	690	20.3	95	148.6	700	11.5	95	
4.0	706.4	610	47.5	95	353.2	750	29.2	95	227.0	850	21.3	95	126.1	900	12.5	95	
4.6	607.7	660	44.2	95	303.8	820	27.5	95	195.3	920	19.8	95	108.5	960	11.5	95	
6.1	459.6	770	39.0	95	229.8	950	24.1	95	147.7	970	15.8	95	82.1	970	8.8	95	
6.8	412.4	810	36.8	95	206.2	990	22.5	95	132.5	1000	14.6	95	73.6	1000	8.1	95	
7.9	353.7	850	33.1	95	176.8	1050	20.5	95	113.7	1100	13.8	95	63.2	1100	7.7	95	
8.9	313.2	890	30.7	95	156.6	1100	19.0	95	100.7	1100	12.2	95	55.9	1100	6.8	95	
9.7	289.2	900	28.7	95	144.6	1100	17.5	95	93.0	1100	11.3	95	51.6	1100	6.3	95	
11.1	253.3	950	26.5	95	126.7	1100	15.4	95	81.4	1100	9.9	95	45.2	1100	5.5	95	
12.4	225.7	1150	28.6	95	112.8	1420	17.7	95	72.5	1600	12.8	95	40.3	1700	7.6	95	
14.5	193.6	1250	26.7	95	96.8	1550	16.5	95	62.2	1700	11.7	95	34.6	1850	7.0	95	
16.3	171.4	1320	24.9	95	85.7	1630	15.4	95	55.1	1800	10.9	95	30.6	1850	6.2	95	
17.7	158.3	1380	24.1	95	79.1	1700	14.8	95	50.9	1800	10.1	95	28.3	1850	5.8	95	
20.2	138.6	1440	22.0	95	69.3	1750	13.4	95	44.6	1850	9.1	95	24.8	1850	5.0	95	
21.7	129.3	1460	20.8	95	64.6	1750	12.5	95	41.6	1850	8.5	95	23.1	1850	4.7	95	
25.4	110.1	1460	17.7	95	55.1	1620	9.8	95	35.4	1720	6.7	95	19.7	1830	4.0	95	
29.1	96.1	1460	15.5	95	48.0	1750	9.3	95	30.9	1850	6.3	95	17.2	1850	3.5	95	
32.3	86.6	1460	13.9	95	43.3	1750	8.4	95	27.8	1850	5.7	95	15.5	1850	3.2	95	
38.9	72.0	1460	11.6	95	36.0	1750	6.9	95	23.1	1850	4.7	95	12.9	1850	2.6	95	
40.7	68.8	1460	11.1	95	34.4	1750	6.6	95	22.1	1800	4.4	95	12.3	1850	2.5	95	
44.7	62.6	1460	10.1	95	31.3	1750	6.0	95	20.1	1800	4.0	95	11.2	1900	2.3	95	
48.9	57.2	1460	9.2	95	28.6	1750	5.5	95	18.4	1850	3.7	95	10.2	1900	2.1	95	

PR 112/3



ir	n ₁ = 2800 min ⁻¹				n ₁ = 1400 min ⁻¹				n ₁ = 900 min ⁻¹				n ₁ = 500 min ⁻¹				IEC
	n ₂ min ⁻¹	T _{2M} Nm	P kW	RD %	n ₂ min ⁻¹	T _{2M} Nm	P kW	RD %	n ₂ min ⁻¹	T _{2M} Nm	P kW	RD %	n ₂ min ⁻¹	T _{2M} Nm	P kW	RD %	
51.2	54.7	1350	8.3	93	27.4	1700	5.2	93	17.6	1860	3.7	93	9.8	1860	2.0	93	112 B5
58.5	47.9	1400	7.5	93	23.9	1750	4.7	93	15.4	1860	3.2	93	8.6	1860	1.8	93	
62.7	44.7	1420	7.1	93	22.3	1750	4.4	93	14.4	1860	3.0	93	8.0	1860	1.7	93	
67.4	41.6	1440	6.7	93	20.8	1750	4.1	93	13.4	1860	2.8	93	7.4	1860	1.6	93	
72.6	38.6	1500	6.5	93	19.3	1750	3.8	93	12.4	1860	2.6	93	6.9	1860	1.4	93	
78.5	35.7	1500	6.0	93	17.8	1750	3.5	93	11.5	1860	2.4	93	6.4	1860	1.3	93	
87.3	32.1	1500	5.4	93	16.0	1750	3.2	93	10.3	1860	2.2	93	5.7	1860	1.2	93	
93.6	29.9	1500	5.1	93	15.0	1750	2.9	93	9.6	1860	2.0	93	5.3	1860	1.1	93	
108.4	25.8	1500	4.4	93	12.9	1750	2.5	93	8.3	1860	1.7	93	4.6	1860	1.0	93	
117.2	23.9	1500	4.0	93	11.9	1750	2.4	93	7.7	1860	1.6	93	4.3	1860	0.9	93	
128.3	21.8	1500	3.7	93	10.9	1750	2.2	93	7.0	1860	1.5	93	3.9	1860	0.8	93	
148.0	18.9	1500	3.2	93	9.5	1750	1.9	93	6.1	1860	1.3	93	3.4	1860	0.7	93	
167.0	16.8	1500	2.8	93	8.4	1750	1.7	93	5.4	1860	1.1	93	3.0	1860	0.6	93	
191.5	14.6	1500	2.5	93	7.3	1750	1.4	93	4.7	1860	1.0	93	2.6	1860	0.5	93	
220.9	12.7	1500	2.1	93	6.3	1750	1.2	93	4.1	1860	0.9	93	2.3	1860	0.5	93	
241.0	11.6	1500	2.0	93	5.8	1750	1.1	93	3.7	1900	0.8	93	2.1	1900	0.4	93	
278.1	10.1	1500	1.7	93	5.0	1750	1.0	93	3.2	1900	0.7	93	1.8	1900	0.4	93	

Pt _N [kW]	tutti i rapporti all ratios alle Untersetzungen
	16.5

N.B.
Per i riduttori evidenziati dal doppio bordo nella colonna delle potenze è necessario verificare lo scambio termico del riduttore (come indicato nel par. A-1.5). Per maggiori informazioni contattare l'ufficio tecnico STM.

NOTE.
Pay attention please to the frame around the input power value: for this gearboxes it's important to check the thermal capacity (comp. par. A-1.5). For details please contact our technical office.

HINWEIS.
Sind in den Tabellen Nennleistungen eingerahmt, so ist die thermische Leistungsgrenze der Getriebe zu beachten (s. par.A-1.5). Für weitere Informationen wenden Sie sich bitte an unser technisches Büro.

N.B.
I pesi riportati sono indicativi e possono variare in funzione della versione del riduttore.

NOTE.
Listed weights are for reference only and can vary according to the gearbox version.

HINWEIS.
Die angegebenen Gewichtsmaße sind Richtwerte und können je nach Getriebeversion variieren.



1.6 Prestazioni riduttori PR

1.6 PR gearboxes performances

1.6 Leistungen der PR-Getriebe

PR 125/2



105

ir	n ₁ = 2800 min ⁻¹				n ₁ = 1400 min ⁻¹				n ₁ = 900 min ⁻¹				n ₁ = 500 min ⁻¹				IEC
	n ₂ min ⁻¹	T _{2M} Nm	P kW	RD %	n ₂ min ⁻¹	T _{2M} Nm	P kW	RD %	n ₂ min ⁻¹	T _{2M} Nm	P kW	RD %	n ₂ min ⁻¹	T _{2M} Nm	P kW	RD %	
5,4	514,7	900,0	51,1	95	257,4	1000,0	28,4	95	165,5	1088,9	19,9	95	91,9	1088,9	11,0	95	200 B5 180 B5 160 B5 132 B5 132 B14 112 B5 100 B5
6,5	427,8	1080,0	50,9	95	213,9	1200,0	28,3	95	137,5	1306,7	19,8	95	76,4	1306,7	11,0	95	
8,2	341,9	1350,0	50,9	95	171,0	1500,0	28,3	95	109,9	1633,3	19,8	95	61,1	1633,3	11,0	95	
9,9	284,2	1440,0	45,1	95	142,1	1600,0	25,1	95	91,3	1742,2	17,5	95	50,7	1742,2	9,7	95	
12,5	223,9	1620,0	40,0	95	111,9	1800,0	22,2	95	72,0	1960,0	15,5	95	40,0	1960,0	8,6	95	
15,1	186,0	1710,0	35,1	95	93,0	1900,0	19,5	95	59,8	2068,9	13,6	95	33,2	2068,9	7,6	95	
19,9	140,9	1800,0	27,9	95	70,4	2000,0	15,5	95	45,3	2177,8	10,9	95	25,2	2177,8	6,0	95	
25,1	111,5	1890,0	23,2	95	55,8	2100,0	12,9	95	35,9	2286,7	9,0	95	19,9	2286,7	5,0	95	
30,2	92,7	1980,0	20,2	95	46,3	2200,0	11,2	95	29,8	2395,6	7,9	95	16,6	2395,6	4,4	95	
38,2	73,3	2070,0	16,7	95	36,7	2300,0	9,3	95	23,6	2504,4	6,5	95	13,1	2504,4	3,6	95	
44,3	63,3	1980,0	13,8	95	31,6	2200,0	7,7	95	20,3	2395,6	5,4	95	11,3	2395,6	3,0	95	
53,1	52,8	1980,0	11,5	95	26,4	2200,0	6,4	95	17,0	2395,6	4,5	95	9,4	2395,6	2,5	95	
57,5	48,7	1980,0	10,6	95	24,3	2200,0	5,9	95	15,7	2395,6	4,1	95	8,7	2395,6	2,3	95	



P _{tN} [kW]	tutti i rapporti all ratios alle Untersetzungen
	21.0

N.B.
Per i riduttori evidenziati dal doppio bordo nella colonna delle potenze è necessario verificare lo scambio termico del riduttore (come indicato nel par. A-1.5). Per maggiori informazioni contattare l'ufficio tecnico STM.

NOTE.
Pay attention please to the frame around the input power value: for this gearboxes it's important to check the thermal capacity (comp. par. A-1.5). For details please contact our technical office.

HINWEIS.
Sind in den Tabellen Nennleistungen eingerahmt, so ist die thermische Leistungsgrenze der Getriebe zu beachten (s. par.A-1.5).
Für weitere Informationen wenden Sie sich bitte an unser technisches Büro.

N.B.
I pesi riportati sono indicativi e possono variare in funzione della versione del riduttore.

NOTE.
Listed weights are for reference only and can vary according to the gearbox version.

HINWEIS.
Die angegebenen Gewichtsmaße sind Richtwerte und können je nach Getriebeversion variieren.



1.7 Prestazioni motoriduttori
PMP - PCP - PMF - PCF

n ₂ min ⁻¹	ir	T ₂ Nm	FS'	PMP - PCP PMF - PCF	
-------------------------------------	----	----------------------	-----	------------------------	--

0.09 kW		n ₁ = 860 min ⁻¹	63B 6
----------------	--	--	-------

64	13.5	13	19.9	63/2	63B 6
60	14.4	14	16.8	63/2	63B 6
51	16.9	16	15.9	63/2	63B 6
43	19.8	19	13.6	63/2	63B 6
36	24.1	23	10.7	63/2	63B 6
33	26.1	25	10.1	63/2	63B 6
27	31.7	30	8.3	63/2	63B 6
23	36.6	35	7.2	63/2	63B 6
19.8	43.4	40	6.2	63/3	63B 6
18.3	47.0	44	5.8	63/3	63B 6
16.1	53.3	50	5.1	63/3	63B 6
15.0	57.2	53	4.8	63/3	63B 6
13.9	61.8	57	4.4	63/3	63B 6
12.4	69.6	65	3.9	63/3	63B 6
11.4	75.4	70	3.6	63/3	63B 6
10.6	81.4	76	3.4	63/3	63B 6
9.7	88.4	82	3.0	63/3	63B 6
8.7	98.9	92	2.7	63/3	63B 6
7.5	114.4	106	2.4	63/3	63B 6
6.4	135.4	126	2.0	63/3	63B 6
5.8	149.1	139	1.8	63/3	63B 6
5.3	163.2	152	3.1	71/3	63B 6
5.2	164.7	153	1.6	63/3	63B 6
4.7	181.3	169	1.5	63/3	63B 6
4.5	191.6	178	2.9	71/3	63B 6
4.0	216.9	202	1.3	63/3	63B 6
3.9	220.8	205	2.5	71/3	63B 6

0.13 kW		n ₁ = 1360 min ⁻¹ n ₁ = 860 min ⁻¹	63A 4 63C 6
----------------	--	---	----------------

94	14.4	12	17.6	63/2	63A 4
80	16.9	15	17.1	63/2	63A 4
69	19.8	17	14.6	63/2	63A 4
56	24.1	21	11.0	63/2	63A 4
52	26.1	23	10.6	63/2	63A 4
43	31.7	27	8.7	63/2	63A 4
37	36.6	32	7.9	63/2	63A 4
31	43.4	37	6.8	63/3	63A 4
26	53.3	45	5.5	63/3	63A 4
24	57.2	49	5.1	63/3	63A 4
22	61.8	52	4.8	63/3	63A 4
19.5	69.6	59	4.2	63/3	63A 4
18.0	75.4	64	3.9	63/3	63A 4
16.7	81.4	69	3.6	63/3	63A 4
15.4	88.4	75	3.3	63/3	63A 4
13.8	98.9	84	3.0	63/3	63A 4
11.9	114.4	97	2.6	63/3	63A 4
10.0	135.4	115	2.2	63/3	63A 4
9.1	149.1	127	2.0	63/3	63A 4
8.3	163.2	139	3.3	71/3	63A 4
8.3	164.7	140	1.8	63/3	63A 4
7.5	181.3	154	1.6	63/3	63A 4
7.1	191.6	163	3.0	71/3	63A 4
6.3	216.9	184	1.4	63/3	63A 4
6.2	220.8	187	2.7	71/3	63A 4
5.3	163.2	219	2.1	71/3	63C 6

1.7 PMP - PCP - PMF - PCF
Gearmotors performances

n ₂ min ⁻¹	ir	T ₂ Nm	FS'	PMP - PCP PMF - PCF	
-------------------------------------	----	----------------------	-----	------------------------	--

0.13 kW		n ₁ = 1360 min ⁻¹ n ₁ = 860 min ⁻¹	63A 4 63C 6
----------------	--	---	----------------

5.2	164.7	221	1.1	63/3	63C 6
4.0	216.9	291	0.9	63/3	63C 6
3.9	220.8	296	1.8	71/3	63C 6

0.18 kW		n ₁ = 1370 min ⁻¹ n ₁ = 870 min ⁻¹	63B 4 71A 6
----------------	--	---	----------------

152	9.0	11	19.6	63/2	63B 4
132	10.4	12	17.7	63/2	63B 4
116	11.8	14	16.7	63/2	63B 4
101	13.5	16	15.5	63/2	63B 4
95	14.4	17	12.8	63/2	63B 4
81	16.9	20	12.4	63/2	63B 4
69	19.8	24	10.6	63/2	63B 4
57	24.1	29	8.0	63/2	63B 4
52	26.1	31	7.7	63/2	63B 4
43	31.7	38	6.4	63/2	63B 4
37	36.6	44	5.7	63/2	63B 4
32	43.4	51	4.9	63/3	63B 4
29	47.0	55	4.6	63/3	63B 4
26	53.3	62	4.0	63/3	63B 4
24	57.2	67	3.7	63/3	63B 4
22	61.8	72	3.5	63/3	63B 4
19.7	69.6	81	3.1	63/3	63B 4
18.2	75.4	88	2.8	63/3	63B 4
16.8	81.4	95	2.6	63/3	63B 4
15.5	88.4	103	2.4	63/3	63B 4
13.9	98.9	115	2.2	63/3	63B 4
12.0	114.4	133	1.9	63/3	63B 4
11.1	123.8	144	3.2	71/3	63B 4
10.2	134.3	157	2.9	71/3	63B 4
10.1	135.4	158	1.6	63/3	63B 4
9.2	149.1	174	1.4	63/3	63B 4
8.9	154.8	181	2.5	71/3	63B 4
8.4	163.2	190	2.4	71/3	63B 4
8.3	164.7	192	1.3	63/3	63B 4
7.6	181.3	212	1.2	63/3	63B 4
7.2	191.6	224	2.2	71/3	63B 4
6.3	216.9	253	1.0	63/3	63B 4
6.2	220.8	258	1.9	71/3	63B 4
5.3	163.2	300	1.6	71/3	71A 6
5.3	164.7	303	0.8	63/3	71A 6
4.9	178.1	327	2.9	90/3	71A 6
3.9	220.8	406	1.3	71/3	71A 6
3.4	253.2	465	2.0	90/3	71A 6

0.22 kW		n ₁ = 1400 min ⁻¹	63C 4
----------------	--	---	-------

467	3.0	4	18.7	63/2	63C 4
359	3.9	6	19.8	63/2	63C 4
280	5.0	7	19.6	63/2	63C 4
226	6.2	9	18.1	63/2	63C 4

1.7 Leistungen der PMP - PCP -
PMF - PCF Getriebemotoren

n ₂ min ⁻¹	ir	T ₂ Nm	FS'	PMP - PCP PMF - PCF	
-------------------------------------	----	----------------------	-----	------------------------	--

0.22 kW		n ₁ = 1400 min ⁻¹	63C 4
----------------	--	---	-------

189	7.4	11	17.1	63/2	63C 4
156	9.0	13	16.4	63/2	63C 4
119	11.8	17	14.0	63/2	63C 4
97	14.4	21	10.7	63/2	63C 4
83	16.9	24	10.4	63/2	63C 4
71	19.8	28	8.9	63/2	63C 4
58	24.1	34	6.7	63/2	63C 4
44	31.7	45	5.3	63/2	63C 4
32	43.4	61	4.1	63/3	63C 4
26	53.3	74	3.4	63/3	63C 4
23	61.8	86	2.9	63/3	63C 4
20	69.6	97	2.6	63/3	63C 4
17.2	81.4	114	2.2	63/3	63C 4
15.8	88.4	123	2.0	63/3	63C 4
14.2	98.9	138	1.8	63/3	63C 4
14.1	99.3	139	3.3	71/3	63C 4
12.2	114.4	160	1.6	63/3	63C 4
11.3	123.8	173	2.7	71/3	63C 4
9.4	149.1	208	1.2	63/3	63C 4
9.0	154.8	216	2.1	71/3	63C 4
7.7	181.3	253	1.0	63/3	63C 4
7.3	191.6	267	1.8	71/3	63C 4
6.5	216.9	303	0.8	63/3	63C 4
6.3	220.8	308	1.6	71/3	63C 4

0.25 kW		n ₁ = 1370 min ⁻¹ n ₁ = 870 min ⁻¹	71A 4 71B 6
----------------	--	---	----------------

457	3.0	5	16.1	63/2	71A 4
351	3.9	6	17.0	63/2	71A 4
319	4.3	7	18.3	63/2	71A 4
274	5.0	8	16.9	63/2	71A 4
245	5.6	9	17.3	63/2	71A 4
211	6.5	11	15.8	63/2	71A 4
185	7.4	12	14.7	63/2	71A 4
171	8.0	13	15.1	63/2	71A 4
152	9.0	15	14.1	63/2	71A 4
132	10.4	17	12.8	63/2	71A 4
116	11.8	20	12.0	63/2	71A 4
95	14.4	24	9.2	63/2	71A 4
81	16.9	28	8.9	63/2	71A 4
69	19.8	33	7.6	63/2	71A 4
57	24.1	40	5.8	63/2	71A 4
52	26.1	43	5.6	63/2	71A 4
43	31.7	52	4.6	63/2	71A 4
37	36.6	61	4.1	63/2	71A 4
32	43.4	70	3.6	63/3	71A 4
29	47.0	76	3.3	63/3	71A 4
24	57.2	93	2.7	63/3	71A 4
22	61.8	100	2.5	63/3	71A 4
19.7	69.6	113	2.2	63/3	71A 4
18.2	75.4	122	2.0	63/3	71A 4
16.8	81.4	132	1.9	63/3	71A 4
15.5	88.4	143	1.7	63/3	71A 4
15.0	91.5	148	3.1	71/3	71A 4
13.9	98.9	160	1.6	63/3	71A 4



1.7 Prestazioni motoriduttori PMP - PCP - PMF - PCF

n ₂ min ⁻¹	ir	T2 Nm	FS'	PMP - PCP PMF - PCF	
-------------------------------------	----	----------	-----	------------------------	--

0.25 kW	n ₁ = 1370 min ⁻¹	71A 4
	n ₁ = 870 min ⁻¹	71B 6

13.8	99.3	161	2.9	71/3	71A 4
12.0	114.4	185	1.3	63/3	71A 4
10.2	134.3	218	2.1	71/3	71A 4
10.1	135.4	219	1.1	63/3	71A 4
9.2	149.1	242	1.0	63/3	71A 4
8.9	154.8	251	1.8	71/3	71A 4
8.4	163.2	265	1.7	71/3	71A 4
8.3	164.7	267	0.9	63/3	71A 4
7.6	181.3	294	0.9	63/3	71A 4
7.2	191.6	311	1.6	71/3	71A 4
6.8	201.0	326	2.8	90/3	71A 4
6.2	220.8	358	1.4	71/3	71A 4
5.4	253.2	410	2.2	90/3	71A 4
5.3	163.2	417	1.1	71/3	71B 6
4.5	191.6	489	1.1	71/3	71B 6
4.3	201.0	513	1.8	90/3	71B 6
3.4	253.2	646	1.5	90/3	71B 6

0.37 kW	n ₁ = 2790 min ⁻¹	63C 2
	n ₁ = 1380 min ⁻¹	71B 4
	n ₁ = 910 min ⁻¹	80A 6
	n ₁ = 880 min ⁻¹	71C 6

715	3.9	5	19.2	63/2	63C 2
649	4.3	5	18.4	63/2	63C 2
558	5.0	6	18.3	63/2	63C 2
498	5.6	7	18.6	63/2	63C 2
460	3.0	7	11.0	63/2	71B 4
431	3.2	8	19.3	71/2	71B 4
354	3.9	9	11.6	63/2	71B 4
321	4.3	10	12.4	63/2	71B 4
276	5.0	12	11.5	63/2	71B 4
246	5.6	14	11.7	63/2	71B 4
223	6.2	15	10.6	63/2	71B 4
212	6.5	16	10.8	63/2	71B 4
173	8.0	19	10.3	63/2	71B 4
153	9.0	22	9.6	63/2	71B 4
133	10.4	25	8.7	63/2	71B 4
117	11.8	29	8.2	63/2	71B 4
102	13.5	33	7.6	63/2	71B 4
96	14.4	35	6.3	63/2	71B 4
82	16.9	41	6.1	63/2	71B 4
70	19.8	48	5.2	63/2	71B 4
57	24.1	59	3.9	63/2	71B 4
53	26.1	63	3.8	63/2	71B 4
44	31.7	77	3.1	63/2	71B 4
38	36.6	89	2.8	63/2	71B 4
32	43.4	103	2.4	63/3	71B 4
29	47.0	112	2.2	63/3	71B 4
26	53.3	127	2.0	63/3	71B 4
23	60.8	145	3.2	71/3	71B 4
22	61.8	147	1.7	63/3	71B 4
19.8	69.6	166	1.5	63/3	71B 4
18.3	75.4	180	2.6	71/3	71B 4
18.3	75.4	180	1.4	63/3	71B 4
15.9	86.8	207	2.2	71/3	71B 4
15.6	88.4	211	1.2	63/3	71B 4

1.7 PMP - PCP - PMF - PCF Gearmotors performances

n ₂ min ⁻¹	ir	T2 Nm	FS'	PMP - PCP PMF - PCF	
-------------------------------------	----	----------	-----	------------------------	--

0.37 kW	n ₁ = 2790 min ⁻¹	63C 2
	n ₁ = 1380 min ⁻¹	71B 4
	n ₁ = 910 min ⁻¹	80A 6
	n ₁ = 880 min ⁻¹	71C 6

14.0	98.9	236	1.1	63/3	71B 4
13.9	99.3	236	1.9	71/3	71B 4
12.8	107.5	256	1.8	71/3	71B 4
12.1	114.4	272	0.9	63/3	71B 4
11.1	123.8	295	1.6	71/3	71B 4
11.0	125.0	298	3.1	90/3	71B 4
10.3	134.3	320	1.4	71/3	71B 4
9.8	141.0	336	2.7	90/3	71B 4
8.9	154.8	369	1.2	71/3	71B 4
8.9	155.2	370	2.5	90/3	71B 4
7.2	191.6	456	1.1	71/3	71B 4
6.9	201.0	479	1.9	90/3	71B 4
6.3	220.8	526	1.0	71/3	71B 4
5.5	253.2	603	1.5	90/3	71B 4
4.4	201.0	751	1.3	90/3	71C 6
4.1	220.9	798	2.3	112/3	80A 6
3.5	253.2	946	1.0	90/3	71C 6
3.3	278.1	1004	1.9	112/3	80A 6

0.55 kW	n ₁ = 2800 min ⁻¹	71B 2
	n ₁ = 1380 min ⁻¹	71C 4
	n ₁ = 1390 min ⁻¹	80A 4
	n ₁ = 910 min ⁻¹	80B 6

933	3.0	5	14.4	63/2	71B 2
718	3.9	7	12.9	63/2	71B 2
651	4.3	8	12.4	63/2	71B 2
531	2.6	9	13.8	71/2	71C 4
460	3.0	11	7.4	63/2	71C 4
431	3.2	12	13.0	71/2	71C 4
363	3.8	14	12.7	71/2	71C 4
354	3.9	14	7.8	63/2	71C 4
321	4.3	16	8.4	63/2	71C 4
276	5.0	18	7.7	63/2	71C 4
246	5.6	20	7.9	63/2	71C 4
223	6.2	22	7.1	63/2	71C 4
212	6.5	24	7.2	63/2	71C 4
186	7.4	27	6.7	63/2	71C 4
173	8.0	29	6.9	63/2	71C 4
153	9.0	33	6.5	63/2	71C 4
133	10.4	38	5.9	63/2	71C 4
117	11.8	43	5.5	63/2	71C 4
102	13.5	49	5.1	63/2	71C 4
96	14.4	52	4.2	63/2	71C 4
82	16.9	61	4.1	63/2	71C 4
70	19.8	72	3.5	63/2	71C 4
67	20.5	74	3.1	63/2	71C 4
57	24.1	87	2.6	63/2	71C 4
53	26.1	94	2.5	63/2	71C 4
44	31.7	115	2.1	63/2	71C 4
42	33.1	120	3.4	71/2	71C 4
38	36.6	132	1.9	63/2	71C 4
37	37.3	135	3.0	71/2	71C 4
35	39.5	140	3.3	71/3	71C 4
32	43.4	154	1.6	63/3	71C 4
31	44.7	162	2.8	71/2	71C 4
29	47.0	166	1.5	63/3	71C 4
27	50.5	183	2.5	71/2	71C 4

1.7 Leistungen der PMP - PCP - PMF - PCF Getriebemotoren

n ₂ min ⁻¹	ir	T2 Nm	FS'	PMP - PCP PMF - PCF	
-------------------------------------	----	----------	-----	------------------------	--

0.55 kW	n ₁ = 2800 min ⁻¹	71B 2
	n ₁ = 1380 min ⁻¹	71C 4
	n ₁ = 1390 min ⁻¹	80A 4
	n ₁ = 910 min ⁻¹	80B 6

26	53.3	189	1.3	63/3	71C 4
26	53.5	189	2.4	71/3	71C 4
23	60.8	215	2.1	71/3	71C 4
22	61.8	219	1.1	63/3	71C 4
21	64.2	227	2.0	71/3	71C 4
19.8	69.6	246	1.0	63/3	71C 4
18.3	75.4	267	1.7	71/3	71C 4
18.3	75.4	267	0.9	63/3	71C 4
18.1	76.3	270	3.4	90/3	71C 4
17.0	81.4	288	0.9	63/3	71C 4
16.7	82.8	293	3.1	90/3	71C 4
15.1	91.5	324	1.4	71/3	71C 4
14.8	93.3	330	2.8	90/3	71C 4
13.9	99.3	351	1.3	71/3	71C 4
13.7	100.6	356	2.6	90/3	71C 4
12.8	107.5	381	1.2	71/3	71C 4
12.7	108.9	385	2.4	90/3	71C 4
11.1	123.8	438	1.0	71/3	71C 4
11.0	125.0	442	2.1	90/3	71C 4
10.3	134.3	475	1.0	71/3	71C 4
9.8	141.0	499	1.8	90/3	71C 4
8.9	154.8	548	0.8	71/3	71C 4
8.9	155.2	549	1.7	90/3	71C 4
8.3	167.0	587	3.0	112/3	80A 4
7.7	178.1	630	1.4	90/3	71C 4
6.3	220.9	776	2.3	112/3	80A 4
6.1	224.4	794	1.1	90/3	71C 4
5.8	241.0	847	2.1	112/3	80A 4
5.5	253.2	896	1.0	90/3	71C 4
4.8	191.5	1028	1.8	112/3	80B 6
4.5	201.0	1079	0.9	90/3	80B 6
3.3	278.1	1493	1.3	112/3	80B 6

0.75 kW	n ₁ = 2800 min ⁻¹	71C 2
	n ₁ = 1390 min ⁻¹	80B 4
	n ₁ = 910 min ⁻¹	80C 6

933	3.0	7	10.6	63/2	71C 2
718	3.9	9	9.5	63/2	71C 2
651	4.3	10	9.1	63/2	71C 2
560	5.0	12	9.1	63/2	71C 2
500	5.6	14	9.2	63/2	71C 2
452	6.2	15	8.6	63/2	71C 2
431	6.5	16	8.5	63/2	71C 2
378	7.4	18	7.8	63/2	71C 2
356	3.9	19	5.8	63/2	80B 4
323	4.3	21	6.2	63/2	80B 4
278	5.0	24	5.7	63/2	80B 4
248	5.6	27	5.8	63/2	80B 4
224	6.2	30	5.3	63/2	80B 4
214	6.5	32	5.3	63/2	80B 4
188	7.4	36	5.0	63/2	80B 4
174	8.0	39	5.1	63/2	80B 4
154	9.0	44	4.8	63/2	80B 4
134	10.4	51	4.3	63/2	80B 4
118	11.8	58	4.1	63/2	80B 4
97	14.4	70	3.1	63/2	80B 4



**1.7 Prestazioni motoriduttori
PMP - PCP - PMF - PCF**

n ₂ min ⁻¹	ir	T ₂ Nm	FS'	PMP - PCP PMF - PCF	
-------------------------------------	----	----------------------	-----	------------------------	--

0.75 kW	n ₁ = 2800 min ⁻¹	71C 2
	n ₁ = 1390 min ⁻¹	80B 4
	n ₁ = 910 min ⁻¹	80C 6

82	16.9	83	3.0	63/2	80B 4
70	19.8	97	2.6	63/2	80B 4
58	24.1	118	1.9	63/2	80B 4
55	25.3	124	3.3	71/2	80B 4
53	26.1	128	1.9	63/2	80B 4
48	28.8	141	3.3	71/2	80B 4
44	31.7	155	1.5	63/2	80B 4
42	33.1	162	2.5	71/2	80B 4
38	36.6	179	1.4	63/2	80B 4
37	37.3	183	2.2	71/2	80B 4
35	39.5	189	2.4	71/3	80B 4
32	43.4	208	1.2	63/3	80B 4
30	47.0	225	1.1	63/3	80B 4
28	50.5	247	1.9	71/2	80B 4
26	53.3	255	1.0	63/3	80B 4
25	55.2	265	3.4	90/3	80B 4
24	57.2	274	0.9	63/3	80B 4
23	60.8	291	1.6	71/3	80B 4
22	61.8	296	0.8	63/3	80B 4
22	62.3	299	3.0	90/3	80B 4
22	64.2	308	1.5	71/3	80B 4
18.4	75.4	361	1.3	71/3	80B 4
18.2	76.3	366	2.5	90/3	80B 4
16.8	82.8	397	2.3	90/3	80B 4
16.0	86.8	416	1.1	71/3	80B 4
15.2	91.5	438	1.0	71/3	80B 4
14.9	93.3	447	2.0	90/3	80B 4
12.9	107.5	515	0.9	71/3	80B 4
12.8	108.4	519	3.4	112/3	80B 4
10.8	128.3	615	2.8	112/3	80B 4
9.9	141.0	676	1.3	90/3	80B 4
8.3	167.0	800	2.2	112/3	80B 4
7.8	178.1	853	1.1	90/3	80B 4
6.3	220.9	1059	1.7	112/3	80B 4
6.2	224.4	1075	0.8	90/3	80B 4
5.0	278.1	1333	1.3	112/3	80B 4
4.1	220.9	1617	1.2	112/3	80C 6
3.3	278.1	2036	0.9	112/3	80C 6

0.88 kW	n ₁ = 1350 min ⁻¹	80C 4

450	3.0	18	4.5	63/2	80C 4
346	3.9	23	4.8	63/2	80C 4
314	4.3	25	5.1	63/2	80C 4
270	5.0	30	4.7	63/2	80C 4
241	5.6	33	4.8	63/2	80C 4
218	6.2	37	4.4	63/2	80C 4
208	6.5	38	4.4	63/2	80C 4
182	7.4	44	4.1	63/2	80C 4
169	8.0	47	4.2	63/2	80C 4
150	9.0	53	3.9	63/2	80C 4
130	10.4	62	3.6	63/2	80C 4
114	11.8	70	3.4	63/2	80C 4
100	13.5	80	3.1	63/2	80C 4
94	14.4	85	2.6	63/2	80C 4

**1.7 PMP - PCP - PMF - PCF
Gearmotors performances**

n ₂ min ⁻¹	ir	T ₂ Nm	FS'	PMP - PCP PMF - PCF	
-------------------------------------	----	----------------------	-----	------------------------	--

0.88 kW	n ₁ = 1350 min ⁻¹	80C 4

80	16.9	100	2.5	63/2	80C 4
68	19.8	117	2.1	63/2	80C 4
66	20.5	121	1.9	63/2	80C 4
56	24.1	143	1.6	63/2	80C 4
53	25.3	150	2.7	71/2	80C 4
43	31.7	187	1.3	63/2	80C 4
41	33.1	196	2.1	71/2	80C 4
34	39.5	229	2.0	71/3	80C 4
31	43.4	251	1.0	63/3	80C 4
29	47.0	272	0.9	63/3	80C 4
28	48.8	283	3.2	90/3	80C 4
27	50.5	299	1.5	71/2	80C 4
22	60.8	352	1.3	71/3	80C 4
22	62.3	361	2.5	90/3	80C 4
17.9	75.4	437	1.1	71/3	80C 4
17.7	76.3	442	2.1	90/3	80C 4
16.3	82.8	479	1.9	90/3	80C 4
15.6	86.8	503	0.9	71/3	80C 4
14.8	91.5	530	0.9	71/3	80C 4
14.5	93.3	540	1.7	90/3	80C 4
14.4	93.6	542	3.2	112/3	80C 4
13.6	99.3	575	0.8	71/3	80C 4
13.4	100.6	582	1.6	90/3	80C 4
12.5	108.4	628	2.8	112/3	80C 4
12.4	108.9	630	1.4	90/3	80C 4
11.5	117.2	679	2.6	112/3	80C 4
10.8	125.0	724	1.3	90/3	80C 4
9.1	148.0	857	2.0	112/3	80C 4
8.7	155.2	899	1.0	90/3	80C 4
7.6	178.1	1031	0.9	90/3	80C 4
7.0	191.5	1109	1.6	112/3	80C 4
6.1	220.9	1279	1.4	112/3	80C 4
4.9	278.1	1610	1.1	112/3	80C 4

1.1 kW	n ₁ = 2830 min ⁻¹	80B 2
	n ₁ = 1390 min ⁻¹	80D 4

943	3.0	11	7.3	63/2	80B 2
726	3.9	14	6.5	63/2	80B 2
658	4.3	15	6.3	63/2	80B 2
566	5.0	18	6.2	63/2	80B 2
505	5.6	20	6.3	63/2	80B 2
463	3.0	22	3.7	63/2	80D 4
356	3.9	28	3.9	63/2	80D 4
323	4.3	31	4.2	63/2	80D 4
278	5.0	36	3.9	63/2	80D 4
248	5.6	40	4.0	63/2	80D 4
224	6.2	45	3.6	63/2	80D 4
214	6.5	47	3.6	63/2	80D 4
188	7.4	53	3.4	63/2	80D 4
174	8.0	57	3.5	63/2	80D 4
154	9.0	65	3.2	63/2	80D 4
134	10.4	75	2.9	63/2	80D 4
118	11.8	85	2.8	63/2	80D 4
103	13.5	97	2.6	63/2	80D 4

**1.7 Leistungen der PMP - PCP -
PMF - PCF Getriebemotoren**

n ₂ min ⁻¹	ir	T ₂ Nm	FS'	PMP - PCP PMF - PCF	
-------------------------------------	----	----------------------	-----	------------------------	--

1.1 kW	n ₁ = 2830 min ⁻¹	80B 2
	n ₁ = 1390 min ⁻¹	80D 4
	n ₁ = 1400 min ⁻¹	90S 4
	n ₁ = 920 min ⁻¹	90L 6

97	14.4	103	2.1	63/2	80D 4
82	16.9	121	2.1	63/2	80D 4
74	18.7	134	3.4	71/2	80D 4
70	19.8	142	1.8	63/2	80D 4
69	20.2	145	3.2	71/2	80D 4
68	20.5	147	1.6	63/2	80D 4
63	21.9	157	2.9	71/2	80D 4
58	24.1	173	1.3	63/2	80D 4
53	26.1	187	1.3	63/2	80D 4
48	28.8	207	2.2	71/2	80D 4
44	31.7	228	1.1	63/2	80D 4
42	33.1	238	1.7	71/2	80D 4
38	36.6	263	1.0	63/2	80D 4
37	37.3	268	1.5	71/2	80D 4
36	38.7	272	3.3	90/3	80D 4
35	39.5	278	1.7	71/3	80D 4
32	43.4	305	0.8	63/3	80D 4
32	43.7	307	3.0	90/3	80D 4
31	44.7	321	1.4	71/2	80D 4
28	48.8	343	2.7	90/3	80D 4
28	50.5	363	1.3	71/2	80D 4
26	53.5	376	1.2	71/3	80D 4
25	55.2	388	2.3	90/3	80D 4
23	60.8	427	1.1	71/3	80D 4
22	62.3	438	2.1	90/3	80D 4
22	64.2	451	1.0	71/3	80D 4
19.7	70.6	496	1.8	90/3	80D 4
19.1	72.6	510	3.4	112/3	80D 4
18.4	75.4	530	0.9	71/3	80D 4
18.2	76.3	536	1.7	90/3	80D 4
17.7	78.5	552	3.2	112/3	80D 4
16.8	82.8	582	1.6	90/3	80D 4
15.9	87.3	614	2.9	112/3	80D 4
14.9	93.3	656	1.4	90/3	80D 4
14.9	93.6	658	2.7	112/3	80D 4
13.8	100.6	707	1.3	90/3	80D 4
12.8	108.4	762	2.3	112/3	80D 4
11.9	117.2	824	2.1	112/3	80D 4
11.1	125.0	879	1.0	90/3	80D 4
10.8	128.3	902	1.9	112/3	80D 4
9.9	141.0	991	0.9	90/3	80D 4
9.4	148.0	1040	1.7	112/3	80D 4
9.0	155.2	1091	0.8	90/3	80D 4
8.3	167.0	1174	1.5	112/3	80D 4
7.3	191.5	1346	1.3	112/3	80D 4
6.3	220.9	1553	1.1	112/3	80D 4
5.8	241.0	1694	1.0	112/3	80D 4
5.0	278.1	1955	0.9	112/3	80D 4



1.7 Prestazioni motoriduttori PMP - PCP - PMF - PCF

Table with 6 columns: n2, ir, T2, FS', PMP - PCP / PMF - PCF, and gearmotor icon.

1.5 kW summary table with n1 values and model numbers 80C 2, 90L 4.

Main performance table for 1.5 kW gearmotors with columns for speed, torque, current, speed ratio, and model.

1.7 PMP - PCP - PMF - PCF Gearmotors performances

Table with 6 columns: n2, ir, T2, FS', PMP - PCP / PMF - PCF, and gearmotor icon.

1.5 kW summary table with n1 values and model numbers 580C 2, 90L 4.

Table with 6 columns: n2, ir, T2, FS', PMP - PCP / PMF - PCF, and gearmotor icon.

1.8 kW summary table with n1 values and model numbers 80D 2, 90LB 4, 100B 6.

Main performance table for 1.8 kW gearmotors with columns for speed, torque, current, speed ratio, and model.

1.7 Leistungen der PMP - PCP - PMF - PCF Getriebemotoren

Table with 6 columns: n2, ir, T2, FS', PMP - PCP / PMF - PCF, and gearmotor icon.

1.8 kW summary table with n1 values and model numbers 80D 2, 90LB 4.

Main performance table for 1.8 kW gearmotors with columns for speed, torque, current, speed ratio, and model.

2.2 kW summary table with n1 values and model numbers 90L 2, 100A 4, 100LB 6.

Main performance table for 2.2 kW gearmotors with columns for speed, torque, current, speed ratio, and model.



1.7 Prestazioni motoriduttori
PMP - PCP - PMF - PCF

n ₂ min ⁻¹	ir	T ₂ Nm	FS'	PMP - PCP PMF - PCF	
-------------------------------------	----	----------------------	-----	------------------------	--

2.2 kW	n ₁ = 2840 min ⁻¹ n ₁ = 1410 min ⁻¹ n ₁ = 940 min ⁻¹	90L 2 100A 4 100BL 6
---------------	--	----------------------------

56	25.0	354	2.6	90/2	100A 4
56	25.3	358	1.1	71/2	100A 4
51	27.7	392	2.3	90/2	100A 4
49	28.8	408	1.1	71/2	100A 4
46	30.5	432	2.1	90/2	100A 4
43	33.1	469	0.9	71/2	100A 4
40	35.0	495	1.7	90/2	100A 4
35	40.4	572	1.3	90/2	100A 4
35	40.7	576	3.0	112/2	100A 4
32	44.3	620	3.5	125	100A 4
28	50.9	721	1.2	90/2	100A 4
28	51.2	710	2.4	112/3	100A 4
27	53.1	7434	3.0	125	100A 4
25	57.5	805	2.7	125	100A 4
23	62.3	863	1.1	90/3	100A 4
22	62.7	869	2.0	112/3	100A 4
21.2	44.3	930	2.4	125	100BL 6
21	67.4	934	1.9	112/3	100A 4
20	141.0	970	0.9	90/3	90L 2
18.5	76.3	1057	0.9	90/3	100A 4
18.0	78.5	1088	1.6	112/3	100A 4
17.7	53.1	1115	2.0	125	100BL 6
16.3	57.5	1208	1.8	125	100BL 6
16.2	87.3	1210	1.4	112/3	100A 4
15.1	93.6	1297	1.3	112/3	100A 4
13.0	108.4	1502	1.2	112/3	100A 4
12.0	117.2	1624	1.1	112/3	100A 4
11.0	128.3	1778	1.0	112/3	100A 4
9.5	148.0	2051	0.9	112/3	100A 4

3 kW	n ₁ = 2840 min ⁻¹ n ₁ = 1420 min ⁻¹ n ₁ = 940 min ⁻¹	90LB 2 100B 4 112B 6
-------------	--	----------------------------

1092	2.6	25	4.8	71/2	90LB 2
947	3.0	29	2.7	63/2	90LB 2
888	3.2	31	4.6	71/2	90LB 2
728	3.9	37	2.4	63/2	90LB 2
660	4.3	41	2.3	63/2	90LB 2
568	5.0	48	2.3	63/2	90LB 2
546	2.6	50	2.6	71/2	100B 4
473	3.0	58	1.4	63/2	100B 4
444	3.2	61	2.4	71/2	100B 4
374	3.8	73	2.4	71/2	100B 4
364	3.9	75	1.5	63/2	100B 4
330	4.3	82	2.4	71/2	100B 4
330	4.3	82	1.6	63/2	100B 4
284	5.0	96	1.5	63/2	100B 4
268	5.3	102	2.1	71/2	100B 4
254	5.6	107	1.5	63/2	100B 4
229	6.2	119	2.2	71/2	100B 4
229	6.2	119	1.3	63/2	100B 4
218	6.5	125	1.4	63/2	100B 4
200	7.1	136	2.2	71/2	100B 4
192	7.4	142	1.3	63/2	100B 4

1.7 PMP - PCP - PMF - PCF
Gearmotors performances

n ₂ min ⁻¹	ir	T ₂ Nm	FS'	PMP - PCP PMF - PCF	
-------------------------------------	----	----------------------	-----	------------------------	--

3 kW	n ₁ = 2840 min ⁻¹ n ₁ = 1420 min ⁻¹ n ₁ = 940 min ⁻¹	90LB 2 100B 4 112B 6
-------------	--	----------------------------

178	8.0	153	1.3	63/2	100B 4
163	8.7	167	3.4	90/2	100B 4
163	8.7	167	1.9	71/2	100B 4
158	9.0	173	1.2	63/2	100B 4
153	9.3	178	3.1	90/2	100B 4
137	10.4	199	1.1	63/2	100B 4
122	11.6	222	1.9	71/2	100B 4
120	11.8	226	1.0	63/2	100B 4
115	12.3	236	1.3	71/2	100B 4
105	13.5	259	1.0	63/2	100B 4
101	14.0	268	3.4	90/2	100B 4
101	14.0	268	1.7	71/2	100B 4
89	16.0	307	3.0	90/2	100B 4
88	16.1	309	1.5	71/2	100B 4
83	17.1	328	2.8	90/2	100B 4
82	17.3	332	1.4	71/2	100B 4
76	18.7	358	1.3	71/2	100B 4
72	19.8	380	2.4	90/2	100B 4
70	20.2	387	1.2	71/2	100B 4
66	21.4	410	2.2	90/2	100B 4
65	21.9	420	1.1	71/2	100B 4
57	25.0	479	1.9	90/2	100B 4
56	25.3	485	0.8	71/2	100B 4
56	25.4	487	3.3	112/2	100B 4
51	27.7	531	1.7	90/2	100B 4
49	28.8	552	0.8	71/2	100B 4
49	29.1	558	3.1	112/2	100B 4
41	35.0	671	1.3	90/2	100B 4
35	40.4	774	0.9	90/2	100B 4
35	40.7	780	2.2	112/2	100B 4
32	44.1	845	1.0	90/2	100B 4
32	44.7	857	2.0	112/2	100B 4
32	44.3	839	2.6	125	100B 4
28	50.9	976	0.9	90/2	100B 4
28	51.2	961	1.8	112/3	100B 4
27	53.1	1007	2.2	125	100B 4
25	57.5	1091	2.0	125	100B 4
23	62.7	1176	1.5	112/3	100B 4
19.6	72.6	1362	1.3	112/3	100B 4
18.1	78.5	1473	1.2	112/3	100B 4
16.3	87.3	1638	1.1	112/3	100B 4
15.2	93.6	1756	1.0	112/3	100B 4
13.1	108.4	2034	0.9	112/3	100B 4

4 kW	n ₁ = 2860 min ⁻¹ n ₁ = 1410 min ⁻¹	100B 2 100BL 4
-------------	--	-------------------

1100	2.6	33	3.6	71/2	100B 2
953	3.0	38	2.0	63/2	100B 2
894	3.2	41	3.4	71/2	100B 2
753	3.8	48	3.3	71/2	100B 2
733	3.9	49	1.8	63/2	100B 2
665	4.3	55	3.3	71/2	100B 2
665	4.3	55	1.7	63/2	100B 2
542	2.6	67	1.9	71/2	100BL 4
470	3.0	77	1.0	63/2	100BL 4

1.7 Leistungen der PMP - PCP -
PMF - PCF Getriebemotoren

n ₂ min ⁻¹	ir	T ₂ Nm	FS'	PMP - PCP PMF - PCF	
-------------------------------------	----	----------------------	-----	------------------------	--

4 kW	n ₁ = 2860 min ⁻¹ n ₁ = 1410 min ⁻¹	100B 2 100BL 4
-------------	--	-------------------

441	3.2	82	1.8	71/2	100BL 4
371	3.8	98	1.8	71/2	100BL 4
362	3.9	100	1.1	63/2	100BL 4
328	4.3	111	1.8	71/2	100BL 4
328	4.3	111	1.2	63/2	100BL 4
282	5.0	129	1.1	63/2	100BL 4
266	5.3	136	1.5	71/2	100BL 4
252	5.6	144	1.1	63/2	100BL 4
227	6.2	160	1.6	71/2	100BL 4
227	6.2	160	1.0	63/2	100BL 4
199	7.1	183	1.6	71/2	100BL 4
191	7.4	190	0.9	63/2	100BL 4
181	7.8	201	3.2	90/2	100BL 4
176	8.0	206	1.0	63/2	100BL 4
162	8.7	224	2.5	90/2	100BL 4
162	8.7	224	1.4	71/2	100BL 4
157	9.0	232	0.9	63/2	100BL 4
147	9.7	247	3.3	90/2	112A 4
138	10.2	263	1.6	71/2	100BL 4
136	10.4	268	0.8	63/2	100BL 4
129	10.9	281	3.1	90/2	100BL 4
122	11.6	299	1.4	71/2	100BL 4
115	12.3	317	2.9	90/2	100BL 4
115	12.3	317	0.9	71/2	100BL 4
101	14.0	360	2.5	90/2	100BL 4
101	14.0	360	1.2	71/2	100BL 4
88	16.0	412	2.2	90/2	100BL 4
88	16.1	414	1.1	71/2	100BL 4
82	17.1	440	2.1	90/2	100BL 4
82	17.3	445	1.0	71/2	100BL 4
75	18.7	481	1.0	71/2	100BL 4
71	19.8	510	1.8	90/2	100BL 4
66	21.4	551	1.7	90/2	100BL 4
64	21.9	564	0.8	71/2	100BL 4
56	25.0	643	1.4	90/2	100BL 4
56	25.1	639	3.3	125	100BL 4
56	25.4	654	2.5	112/2	100BL 4
51	27.7	713	1.3	90/2	100BL 4
48	29.1	749	2.3	112/2	100BL 4
47	30.2	769	2.9	125	100BL 4
46	30.5	785	1.2	90/2	100BL 4
40	35.0	901	0.9	90/2	100BL 4
37	38.2	972	2.4	125	100BL 4
36	38.9	1001	1.7	112/2	100BL 4
32	43.7	1101	0.8	90/3	100BL 4
32	44.3	1127	2.0	125	100BL 4
32	44.7	1150	1.5	112/2	100BL 4
28	51.2	1290	1.3	112/3	100BL 4
27	53.1	1352	1.6	125	100BL 4
25	57.5	1464	1.5	125	100BL 4
24	58.5	1474	1.2	112/3	100BL 4
21	67.4	1698	1.0	112/3	100BL 4
19.4	72.6	1829	1.0	112/3	100BL 4
18.0	78.5	1978	0.9	112/3	100BL 4



1.7 Prestazioni motoriduttori PMP - PCP - PMF - PCF

n ₂ min ⁻¹	ir	T ₂ Nm	FS'	PMP - PCP PMF - PCF	
-------------------------------------	----	----------------------	-----	------------------------	--

5.5 kW	n ₁ = 2880 min ⁻¹ n ₁ = 1400 min ⁻¹	112B 2 112BL 4
---------------	--	-------------------

1108	2.6	45	2.7	71/2	112B 2
960	3.0	52	1.5	63/2	112B 2
900	3.2	55	2.5	71/2	112B 2
758	3.8	66	2.4	71/2	112B 2
738	3.9	68	1.3	63/2	112B 2
670	4.3	75	2.4	71/2	112B 2
670	4.3	75	1.3	63/2	112B 2
576	5.0	87	1.3	63/2	112B 2
543	5.3	92	2.0	71/2	112B 2
538	2.6	93	1.4	71/2	112BL 4
519	2.7	96	3.4	90/2	112BL 4
438	3.2	114	1.3	71/2	112BL 4
368	3.8	135	1.3	71/2	112BL 4
333	4.2	150	3.2	90/2	112BL 4
326	4.3	153	1.3	71/2	112BL 4
326	4.3	153	0.8	63/2	112BL 4
264	5.3	189	2.8	90/2	112BL 4
264	5.3	189	1.1	71/2	112BL 4
250	5.6	200	0.8	63/2	112BL 4
237	5.9	210	2.7	90/2	112BL 4
226	6.2	221	1.2	71/2	112BL 4
209	6.7	239	2.5	90/2	112BL 4
197	7.1	253	1.2	71/2	112BL 4
179	7.8	278	2.3	90/2	112BL 4
161	8.7	310	1.8	90/2	112BL 4
161	8.7	310	1.0	71/2	112BL 4
151	9.3	331	1.7	90/2	112BL 4
144	9.7	346	3.2	112/2	112BL 4
137	10.2	364	1.2	71/2	112BL 4
128	10.9	388	2.2	90/2	112BL 4
126	11.1	396	2.8	112/2	112BL 4
114	12.3	438	2.1	90/2	112BL 4
113	12.4	442	3.2	112/2	112BL 4
100	14.0	499	1.8	90/2	112BL 4
100	14.0	499	0.9	71/2	112BL 4
97	14.5	517	3.0	112/2	112BL 4
93	15.1	531	3.6	125	112BL 4
88	16.0	570	1.6	90/2	112BL 4
87	16.1	574	0.8	71/2	112BL 4
86	16.3	581	2.8	112/2	112BL 4
82	17.1	609	1.5	90/2	112BL 4
79	17.7	631	2.7	112/2	112BL 4
71	19.8	706	1.3	90/2	112BL 4
70	19.9	701	2.9	125	112BL 4
69	20.2	720	2.4	112/2	112BL 4
65	21.4	763	1.2	90/2	112BL 4
65	21.7	773	2.3	112/2	112BL 4
56	25.0	891	1.0	90/2	112BL 4
56	25.1	885	2.4	125	112BL 4
55	25.4	905	1.8	112/2	112BL 4
48	29.1	1037	1.7	112/2	112BL 4
46	30.2	1065	2.1	125	112BL 4
46	30.5	1087	0.8	90/2	112BL 4
43	32.3	1151	1.5	112/2	112BL 4
37	38.2	1347	1.7	125	112BL 4
36	38.9	1386	1.3	112/2	112BL 4
34	40.7	1451	1.2	112/2	112BL 4
32	44.3	1561	1.4	125	112BL 4
31	44.7	1593	1.1	112/2	112BL 4

1.7 PMP - PCP - PMF - PCF Gearmotors performances

n ₂ min ⁻¹	ir	T ₂ Nm	FS'	PMP - PCP PMF - PCF	
-------------------------------------	----	----------------------	-----	------------------------	--

5.5 kW	n ₁ = 2880 min ⁻¹ n ₁ = 1400 min ⁻¹	112B 2 112BL 4
---------------	--	-------------------

29	48.9	1743	1.0	112/2	112BL 4
26	53.1	1872	1.2	125	112BL 4
24	57.5	2028	1.1	125	112BL 4
24	58.5	2041	0.9	112/3	112BL 4

7.5 kW	n ₁ = 2860 min ⁻¹ n ₁ = 1440 min ⁻¹	112BL 2 132M 4
---------------	--	-------------------

1100	2.6	62	1.9	71/2*	112BL 2
953	3.0	71	1.1	63/2*	112BL 2
894	3.2	76	1.8	71/2*	112BL 2
753	3.8	90	1.8	71/2*	112BL 2
733	3.9	93	1.0	63/2*	112BL 2
665	4.3	102	1.8	71/2*	112BL 2
665	4.3	102	0.9	63/2*	112BL 2
572	5.0	119	0.9	63/2*	112BL 2
540	5.3	126	1.4	71/2*	112BL 2
533	2.7	128	2.6	90/2	132M 4
485	5.9	140	3.2	90/2	112BL 2
461	6.2	148	1.6	71/2*	112BL 2
461	6.2	148	0.9	63/2*	112BL 2
403	7.1	169	1.6	71/2*	112BL 2
367	7.8	186	2.8	90/2	112BL 2
343	4.2	198	2.4	90/2	132M 4
272	5.3	250	2.1	90/2	132M 4
244	5.9	279	2.0	90/2	132M 4
236	6.1	288	3.3	112/2	132M 4
215	6.7	317	1.9	90/2	132M 4
212	6.8	321	3.1	112/2	132M 4
185	7.8	369	1.8	90/2	132M 4
182	7.9	373	2.8	112/2	132M 4
166	8.7	411	1.4	90/2	132M 4
162	8.9	421	2.6	112/2	132M 4
148	9.7	458	2.4	112/2	132M 4
148	9.7	458	1.8	90/2	132M 4
132	10.9	515	1.7	90/2	132M 4
130	11.1	525	2.1	112/2	132M 4
117	12.3	581	1.6	90/2	132M 4
116	12.4	586	2.4	112/2	132M 4
115	12.5	585	3.1	125	132M 4
103	14.0	662	1.4	90/2	132M 4
99	14.5	685	2.3	112/2	132M 4
96	15.1	704	2.7	125	132M 4
90	16.0	756	1.2	90/2	132M 4
88	16.3	770	2.1	112/2	132M 4
84	17.1	808	1.1	90/2	132M 4
81	17.7	836	2.0	112/2	132M 4
73	19.8	936	1.0	90/2	132M 4
72	19.9	929	2.2	125	132M 4
71	20.2	955	1.8	112/2	132M 4
67	21.4	1011	0.9	90/2	132M 4
66	21.7	1025	1.7	112/2	132M 4
57	25.1	1174	1.8	125	132M 4
57	25.4	1200	1.3	112/2	132M 4
49	29.1	1375	1.3	112/2	132M 4
48	30.2	1412	1.6	125	132M 4

1.7 Leistungen der PMP - PCP - PMF - PCF Getriebemotoren

n ₂ min ⁻¹	ir	T ₂ Nm	FS'	PMP - PCP PMF - PCF	
-------------------------------------	----	----------------------	-----	------------------------	--

7.5 kW	n ₁ = 2860 min ⁻¹ n ₁ = 1440 min ⁻¹	112BL 2 132M 4
---------------	--	-------------------

45	32.3	1526	1.1	112/2	132M 4
38	38.2	1785	1.3	125	132M 4
37	38.9	1838	1.0	112/2	132M 4
35	40.7	1923	0.9	112/2	132M 4
33	44.3	2069	1.1	125	132M 4
32	44.7	2112	0.8	112/2	132M 4
27	53.1	2482	0.9	125	132M 4
25	57.5	2688	0.8	125	132M 4

9.2 kW	n ₁ = 1450 min ⁻¹	132ML 4
---------------	---	---------

537	2.7	155	2.1	90/2	132ML 4
426	3.4	196	3.3	112/2	132ML 4
363	4.0	230	3.3	112/2	132ML 4
345	4.2	242	2.0	90/2	132ML 4
315	4.6	265	3.1	112/2	132ML 4
274	5.3	305	1.7	90/2	132ML 4
246	5.9	340	1.6	90/2	132ML 4
238	6.1	351	2.7	112/2	132ML 4
216	6.7	386	1.6	90/2	132ML 4
213	6.8	391	2.5	112/2	132ML 4
186	7.8	449	1.4	90/2	132ML 4
184	7.9	455	2.3	112/2	132ML 4
167	8.7	501	1.1	90/2	132ML 4
163	8.9	512	2.1	112/2	132ML 4
156	9.3	535	1.0	90/2	132ML 4
149	9.7	558	2.0	112/2	132ML 4
149	9.7	558	1.5	90/2	132ML 4
147	9.9	561	2.9	125	132ML 4
133	10.9	627	1.4	90/2	132ML 4
131	11.1	639	1.7	112/2	132ML 4
118	12.3	708	1.3	90/2	132ML 4
117	12.4	714	2.0	112/2	132ML 4
116	12.5	712	2.5	125	132ML 4
104	14.0	806	1.1	90/2	132ML 4
100	14.5	835	1.9	112/2	132ML 4
96	15.1	857	2.2	125	132ML 4
91	16.0	921	1.0	90/2	132ML 4
89	16.3	938	1.7	112/2	132ML 4
85	17.1	984	0.9	90/2	132ML 4
82	17.7	1019	1.7	112/2	132ML 4
73	19.9	1132	1.8	125	132ML 4
72	20.2	1163	1.5	112/2	132ML 4
67	21.7	1249	1.4	112/2	132ML 4
58	25.1	1430	1.5	125	132ML 4
57	25.4	1462	1.1	112/2	132ML 4
50	29.1	1675	1.0	112/2	132ML 4
48	30.2	1720	1.3	125	132ML 4
45	32.3	1859	0.9	112/2	132ML 4
38	38.2	2175	1.1	125	132ML 4
33	44.3	2520	0.9	125	132ML 4
27	53.1	3023	0.7	125	132ML 4
25	57.5	3275	0.7	125	132ML 4



**1.7 Prestazioni motoriduttori
PMP - PCP - PMF - PCF**

n ₂ min ⁻¹	ir	T ₂ Nm	FS'	PMP - PCP PMF - PCF	
-------------------------------------	----	----------------------	-----	------------------------	--

11 kW	n ₁ = 2940 min ⁻¹ n ₁ = 1455 min ⁻¹	132M 2 160M 4
--------------	--	------------------

1089	2,7	92	2,9	90/2*	132M 2
865	3,4	115	4,5	112/2	132M 2
700	4,2	143	2,7	90/2*	132M 2
555	5,3	180	2,4	90/2*	132M 2
502	2,9	199	3,0	112/2	160M 4
428	3,4	233	2,7	112/2	160M 4
364	4,0	274	2,7	112/2	160M 4
316	4,6	316	2,6	112/2	160M 4
267	5,4	369	2,7	125	160M 4
239	6,1	418	2,3	112/2	160M 4
222	6,5	444	2,7	125	160M 4
214	6,8	466	2,1	112/2	160M 4
184	7,9	542	1,9	112/2	160M 4
178	8,2	556	2,7	125	160M 4
163	8,9	610	1,8	112/2	160M 4
150	9,7	665	1,7	112/2	160M 4
148	9,9	669	2,4	125	160M 4
131	11,1	761	1,4	112/2	160M 4
117	12,4	851	1,7	112/2	160M 4
116	12,5	849	2,1	125	160M 4
100	14,5	995	1,6	112/2	160M 4
97	15,1	1021	1,9	125	160M 4
89	16,3	1118	1,5	112/2	160M 4
82	17,7	1214	1,4	112/2	160M 4
73	19,9	1349	1,5	125	160M 4
72	20,2	1386	1,3	112/2	160M 4
67	21,7	1488	1,2	112/2	160M 4
58	25,1	1704	1,2	125	160M 4
57	25,4	1742	0,9	112/2	160M 4
50	29,1	1996	0,9	112/2	160M 4
48	30,2	2050	1,1	125	160M 4
38	38,2	2591	0,9	125	160M 4
33	44,3	3003	0,7	125	160M 4

15 kW	n ₁ = 2900 min ⁻¹ n ₁ = 1455 min ⁻¹	132ML 2 160L 4
--------------	--	-------------------

1074	2,7	127	2,1	90/2*	132ML 2
853	3,4	160	3,3	112/2	132ML 2
725	4,0	188	3,2	112/2	132ML 2
690	4,2	197	2,0	90/2*	132ML 2
630	4,6	216	3,1	112/2	132ML 2
547	5,3	249	1,7	90/2*	132ML 2
502	2,9	271	2,2	112/2	160L 4
428	3,4	318	2,0	112/2	160L 4
364	4,0	374	2,0	112/2	160L 4
316	4,6	430	1,9	112/2	160L 4
267	5,4	503	2,0	125	160L 4
239	6,1	571	1,7	112/2	160L 4
222	6,5	606	2,0	125	160L 4
214	6,8	636	1,6	112/2	160L 4
184	7,9	739	1,4	112/2	160L 4
178	8,2	758	2,0	125	160L 4
163	8,9	832	1,3	112/2	160L 4
150	9,7	907	1,2	112/2	160L 4
148	9,9	912	1,8	125	160L 4
131	11,1	1038	1,1	112/2	160L 4

**1.7 PMP - PCP - PMF - PCF
Gearmotors performances**

n ₂ min ⁻¹	ir	T ₂ Nm	FS'	PMP - PCP PMF - PCF	
-------------------------------------	----	----------------------	-----	------------------------	--

15 kW	n ₁ = 2900 min ⁻¹ n ₁ = 1455 min ⁻¹	132ML 2 160L 4
--------------	--	-------------------

117	12,4	1160	1,2	112/2	160L 4
116	12,5	1158	1,6	125	160L 4
100	14,5	1356	1,1	112/2	160L 4
97	15,1	1393	1,4	125	160L 4
89	16,3	1525	1,1	112/2	160L 4
82	17,7	1655	1,0	112/2	160L 4
73	19,9	1840	1,1	125	160L 4
72	20,2	1889	0,9	112/2	160L 4
67	21,7	2030	0,9	112/2	160L 4
58	25,1	2323	0,9	125	160L 4
48	30,2	2795	0,8	125	160L 4
38	38,2	3534	0,7	125	160L 4

18.5 kW	n ₁ = 2910 min ⁻¹ n ₁ = 1460 min ⁻¹ n ₁ = 970 min ⁻¹	160L 2 180M 4 200L 6
----------------	--	----------------------------

1003	2,9	167	2,9	112/2*	160L 2
856	3,4	196	2,7	112/2*	160L 2
728	4,0	231	2,6	112/2*	160L 2
633	4,6	265	2,5	112/2*	160L 2
535	5,4	310	2,9	125	160L 2
477	6,1	352	2,2	112/2*	160L 2
445	6,5	374	2,9	125	160L 2
428	6,8	392	2,1	112/2*	160L 2
368	7,9	456	1,9	112/2*	160L 2
355	8,2	467	2,9	125	160L 2
327	8,9	513	1,7	112/2*	160L 2
300	9,7	559	1,6	112/2*	160L 2
295	9,9	562	2,6	125	160L 2
268	5,4	635	1,6	125	180M 4
262	11,1	640	1,5	112/2*	160L 2
235	12,4	715	1,6	112/2*	160L 2
223	6,5	765	1,6	125	180M 4
201	14,5	836	1,5	112/2*	160L 2
179	16,3	940	1,4	112/2*	160L 2
178	8,2	957	1,6	125	180M 4
164	17,7	1021	1,4	112/2*	160L 2
148	9,9	1151	1,4	125	180M 4
144	20,2	1165	1,2	112/2*	160L 2
134	21,7	1252	1,2	112/2*	160L 2
117	12,5	1461	1,2	125	180M 4
115	25,4	1465	1,0	112/2*	160L 2
100	29,1	1678	0,9	112/2*	160L 2
97	15,1	1758	1,1	125	180M 4
73	19,9	2322	0,9	125	180M 4
58	25,1	2933	0,7	125	180M 4

22 kW	n ₁ = 2925 min ⁻¹ n ₁ = 1460 min ⁻¹ n ₁ = 975 min ⁻¹	180M 2 180L 4 200L 6
--------------	--	----------------------------

538	5,4	367	2,5	125*	180M 2
447	6,5	442	2,5	125*	180M 2
357	8,2	553	2,5	125*	180M 2
297	9,9	665	2,2	125*	180M 2
268	5,4	736	1,4	125*	180L 4
223	6,5	885	1,4	125*	180L 4

**1.7 Leistungen der PMP - PCP -
PMF - PCF Getriebemotoren**

n ₂ min ⁻¹	ir	T ₂ Nm	FS'	PMP - PCP PMF - PCF	
-------------------------------------	----	----------------------	-----	------------------------	--

22 kW	n ₁ = 2925 min ⁻¹ n ₁ = 1460 min ⁻¹ n ₁ = 975 min ⁻¹	180M 2 180L 4 200L 6
--------------	--	----------------------------

178	8,2	1108	1,4	125*	180L 4
148	9,9	1333	1,2	125*	180L 4
117	12,5	1692	1,1	125*	180L 4
97	15,1	2036	0,9	125*	180L 4
73	19,9	2689	0,7	125*	180L 4

30 kW	n ₁ = 2945 min ⁻¹ n ₁ = 1465 min ⁻¹	200L 2 200L 4
--------------	--	------------------

541	5,4	497	1,8	125*	200L 2
450	6,5	599	1,8	125*	200L 2
360	8,2	749	1,8	125*	200L 2
299	9,9	901	1,6	125*	200L 2
269	5,4	1000	1,0	125*	200L 4
224	6,5	1203	1,0	125*	200L 4
179	8,2	1505	1,0	125*	200L 4
149	9,9	1811	0,9	125*	200L 4
117	12,5	2299	0,8	125*	200L 4
97	15,1	2767	0,7	125*	200L 4

37 kW	n ₁ = 2950 min ⁻¹ n ₁ = 1475 min ⁻¹	200L 2 225S 4
--------------	--	------------------

542	5,4	612	1,5	125*	200L 2
451	6,5	737	1,5	125*	200L 2
360	8,2	922	1,5	125*	200L 2
299	9,9	1109	1,3	125*	200L 2
236	12,5	1408	1,2	125*	200L 2
196	15,1	1695	1,0	125*	200L 2
148	19,9	2238	0,8	125*	200L 2
118	25,1	2826	0,7	125*	200L 2

N.B.
Tutte le potenze indicate si riferiscono alla potenza meccanica dei riduttori. Per i riduttori contrassegnati con (*) è opportuno effettuare la verifica della potenza limite termico secondo le indicazioni riportate nel par. A-1.7.

NOTE.
The indicated power is based on the mechanical capacities of the gearboxes. For the gearboxes marked with (*) it is also necessary to obey the thermal capacity like shown on chapter A-1.7.

HINWEIS.
Die Leistungsangaben beziehen sich auf die mechanische Belasbarkeit der Getriebe. Bei den mit (*) gekennzeichneten Getrieben ist außerdem die thermische Leistungsgrenze zu beachten (s. Kap. A-1.7).



E





1.8 Dimensioni

1.8 Dimensions

1.8 Abmessungen

PMP

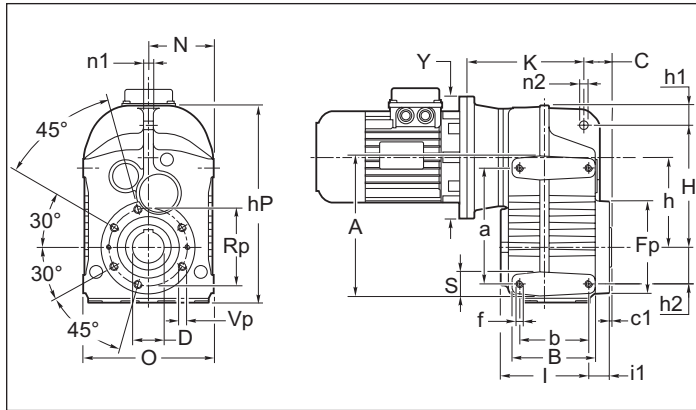

PMF

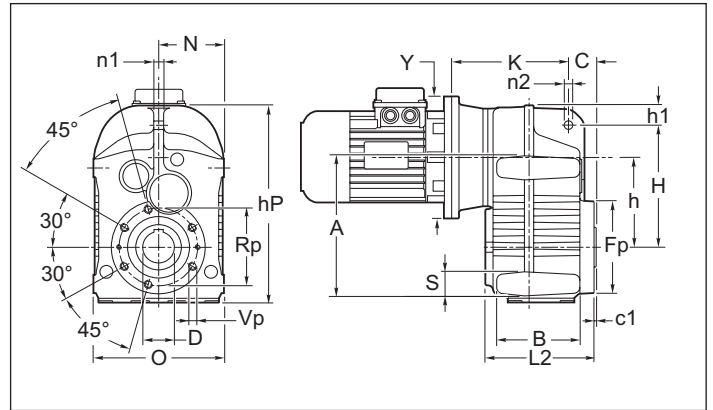

PMP F1 - F2

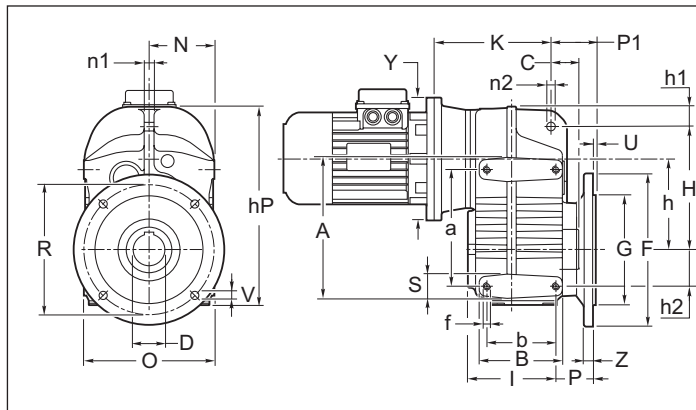

PMF F1 - F2

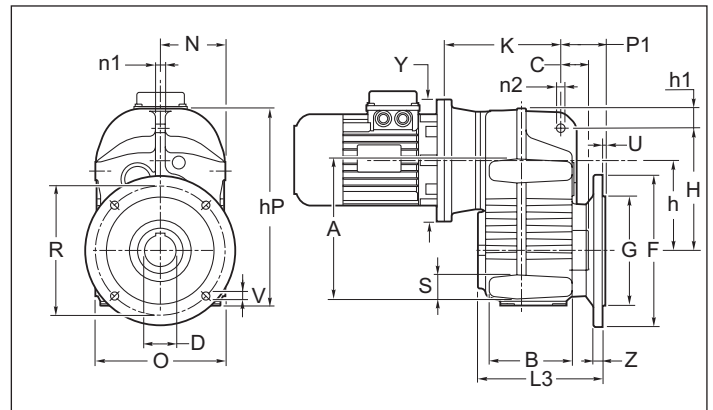

PMP P

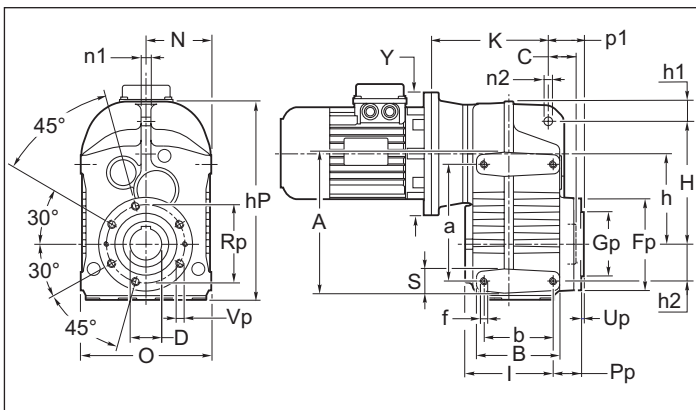

PMF P

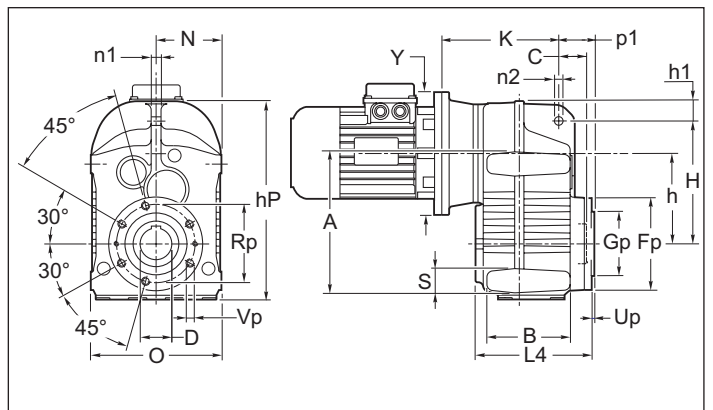

Particolare dei fori nella Flangia - "P"
Detail holes of the flange - "P"

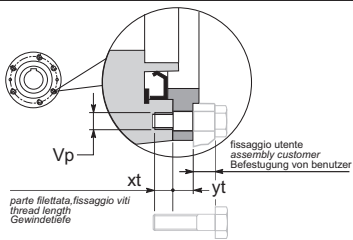

Per il fissaggio al riduttore con i fori "Vp" considerare la lunghezza delle viti adeguate, e che la quota "yt" non è filettata (vedi disegno).

When P-flange is used please consider that the threads "Vp" are in gearbox and that distance "yt" does not have a thread (see drawing).

Bei Verwendung des P-Flansches ist zu beachten, daß sich die Gewinde im Getriebegehäuse befinden und daß Maß "yt" kein Gewinde besitzt. Details siehe Zeichnung.

	Vp	xt	yt
63	N°6 M6	12	11,5
71	N°6 M8	15	11
90	N°6 M12	18	12
112	N°6 M14	23	14



1.8 Dimensioni

1.8 Dimensions

1.8 Abmessungen

P.P P.F	a	A	b	B	C	c1	D H7	f	h	hP	H	h1	h2	I	I1	L2	L3	L4	N	n1	n2
63	115	135	77	95	31.5	2.5	30 (25) (28)	N° 8 M8x12	103. 5	240	152	23.5	31	96.5	20	116.5	143	128	P.F 84.5 P.P 82.5	12	14
71	145	170	93	120	35	3	35 (30) (32)	N° 8 M10x15	117	268	165	26	43	119	28	147	175	158	P.F 92 P.P 90	12	14
90	190	220	112	135	45	3.5	40 (42) (45) (48)	N° 8 M12x17	147	324	200	33	60	143	33.5	176.5	203.5	188.5	P.F 109 P.P 106	16	14
112	240	280	140	166	50	4	50 (55)	N° 8 M16x23	184	400	255	35.5	70	172.5	32.5	205	246	219	P.F 138 P.P 135	20	22
125	310	350	125	158	44.5	2.5	55 (60) (50)	N°8 M16x30	222	502	310	45	100	157	27	169	247	169	P.P 152.5	24	22

P.P P.F	S	Fp	Gp	O	p1	P1	Pp	Rp	Up	Vp	F	G g6	P	R	U	V	Z	
63	20	105	80	P.F 169	43.5	59	31.5	90	3	N°6 M6x12	F1	160	110	46.5	130	3.5	N°4 φ 9	10
				F2							—	—	—		—			
71	25	120	80	P.F 184	46	63.5	39	100	3	N°6 M8x14	F1	200	130	56	165	3.5	N°4 φ 11	12
				F2							160	110	130		3.5	N°4 φ 9.5	10	
90	30	150	105	P.F 218	57	72	45.5	125	3.5	N°6 M12x18	F1	250	180	60.5	215	4	N°4 φ 13.5	15
				F2							—	—	—		—	—		
112	40	175	125	P.F 276	63	91	46.5	150	3.5	N°6 M14x21	F1	300	230	73.5	265	4	N°4 φ 13.5	16
				F2							—	—	—		—	—		
125	40	200	140	305	42	110	21	165	6	N°8 M12x20	F1	350	250	90	300	5	N°4 ø 18	18

PM 2 stages	IEC	Y	63 K	71 K	90 K	112 K	125 K
	63 B5	140	119.5	-	-	-	-
71 B5	160	139.5*	-	-	-	-	
80 B5	200	139.5	-	-	-	-	
80 B14	120	139.5	159	-	-	-	
90 B5	200	139.5	-	-	205	-	
90 B14	140	139.5	-	-	-	-	
100-112 B5	250	149.5	169	-	205	255	204
100-112 B14	160	149.5	-	-	-	-	-
132 B5	300	-	-	-	205	255	204
132 B14	200	-	-	-	-	-	-
160 B5	350	-	-	-	-	255	268
180 B5	350	-	-	-	-	-	268
200 B5	400	-	-	-	-	-	273

PM 3 stages	IEC	Y	63 K	71 K	90 K	112 K
	63 B5	140	124.5	153	-	-
71 B5	160	128.5	153	173*	175	-
80 B5	200	152.5	-	-	-	219.5
80 B14	120	152.5	-	173	190	-
90 B5	200	152.5	-	-	-	219.5
90 B14	140	152.5	-	-	-	-
100-112 B5	250	152.5	-	-	-	229.5
100-112 B14	160	152.5	-	-	200	-
132 B5	300	152.5	-	-	-	-
132 B14	200	152.5	-	-	-	-
160 B5	350	152.5	-	-	-	-

* Con calettatore in posizione standard.

* With shrink disc in standard positions.

* Mit Schrumpfscheibe in Standardposition.



1.8 Dimensioni

1.8 Dimensions

1.8 Abmessungen

PCP

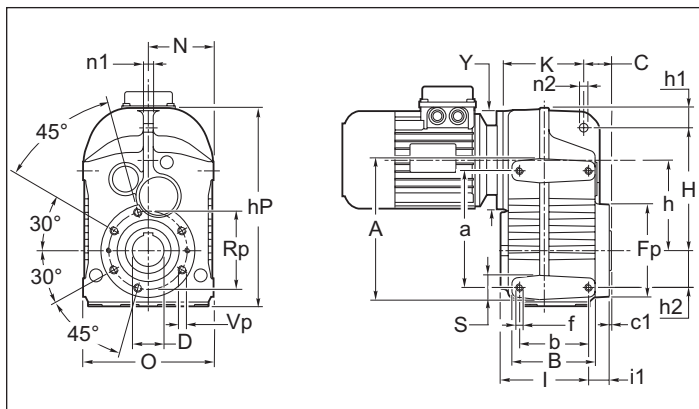

PCF

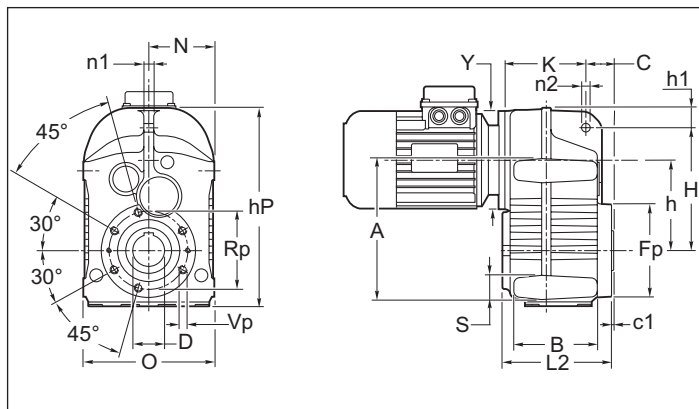

PCP F1 - F2

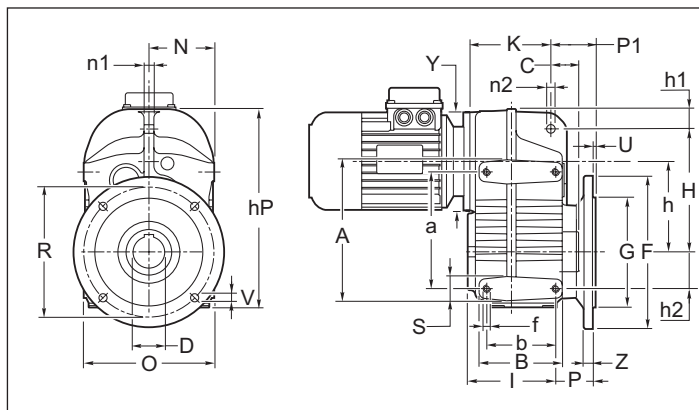

PCF F1 - F2

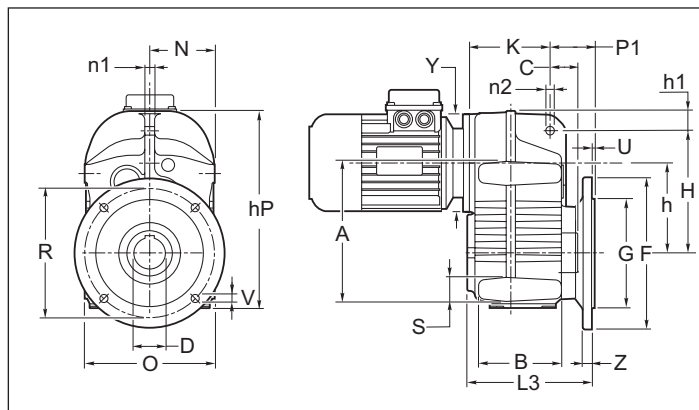

PCP P

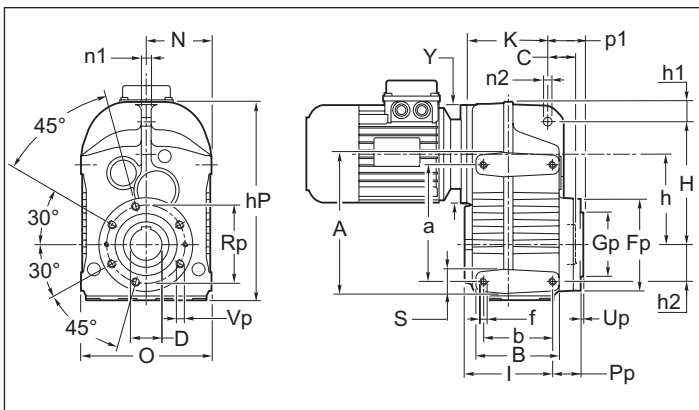

PCF P

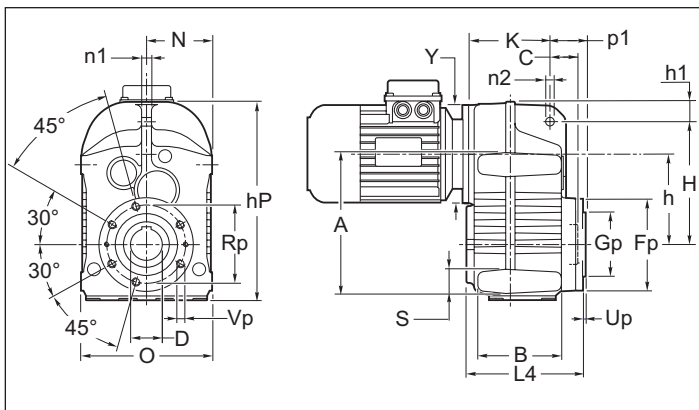

Particolare dei fori nella Flangia - "P"
Detail holes of the flange - "P"

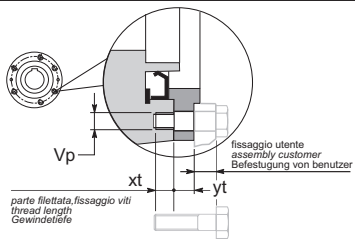

Per il fissaggio al riduttore con i fori "Vp" considerare la lunghezza delle viti adeguate, e che la quota "yt" non è filettata (vedi disegno).

When P-flange is used please consider that the threads "Vp" are in gearcase and that distance "yt" does not have a thread (see drawing).

Bei Verwendung des P-Flansches ist zu beachten, daß sich die Gewinde im Getriebegehäuse befinden und daß Maß "yt" kein Gewinde besitzt. Details siehe Zeichnung.

	Vp	xt	yt
63	N°6 M6	12	11,5
71	N°6 M8	15	11
90	N°6 M12	18	12
112	N°6 M14	23	14



1.8 Dimensioni

1.8 Dimensions

1.8 Abmessungen

P.P P.F	a	A	b	B	C	c1	D H7	f	h	hP	H	h1	h2	I	I1	L2	L3	L4	N	n1	n2
63	115	135	77	95	31.5	2.5	30 (25) (28)	N° 8 M8x12	103.5	240	152	23.5	31	96.5	20	116.5	143	128	P.F 84.5	12	14
																			P.P 82.5		
71	145	170	93	120	35	3	35 (30) (32)	N° 8 M10x15	117	268	165	26	43	119	28	147	175	158	P.F 92	12	14
																			P.P 90		
90	190	220	112	135	45	3.5	40 (42) (45) (48)	N° 8 M12x17	147	324	200	33	60	143	33.5	176.5	203.5	188.5	P.F 109	16	14
																			P.P 106		
112	240	280	140	166	50	4	50 (55)	N° 8 M16x23	184	400	255	35.5	70	172.5	32.5	205	246	219	P.F 138	20	22
																			P.P 135		

P.P P.F	S	Fp	Gp	O	p1	P1	Pp	Rp	Up	Vp	F	G g6	P	R	U	V	Z	
63	20	105	80	P.F 169	43.5	59	31.5	90	3	N°6 M6x12	F1	160	110	46.5	130	3.5	N°4 φ 9	10
				F2							—	—	—		—	—		
71	25	120	80	P.F 184	46	63.5	39	100	3	N°6 M8x14	F1	200	130	56	165	3.5	N°4 φ 11	12
				F2							160	110	130		3.5	N°4 φ 9.5	10	
90	30	150	105	P.F 218	57	72	45.5	125	3.5	N°6 M12x18	F1	250	180	60.5	215	4	N°4 φ 13.5	15
				F2							—	—	—		—	—		
112	40	175	125	P.F 276	63	91	46.5	150	3.5	N°6 M14x21	F1	300	230	73.5	265	4	N°4 φ 13.5	16
				F2							—	—	—		—	—		

PC. 2 stadi	63		71		90		112	
	Y	K (PC.)	Y	K (PC.)	Y	K (PC.)	Y	K (PC.)
	140	81	140	114	160	131	200	163

PC. 3 stadi	63		71		90		112	
	Y	K (PC.)	Y	K (PC.)	Y	K (PC.)	Y	K (PC.)
	140	98	140	114	160	131	200	163



1.8 Dimensioni

1.8 Dimensions

1.8 Abmessungen

PRP

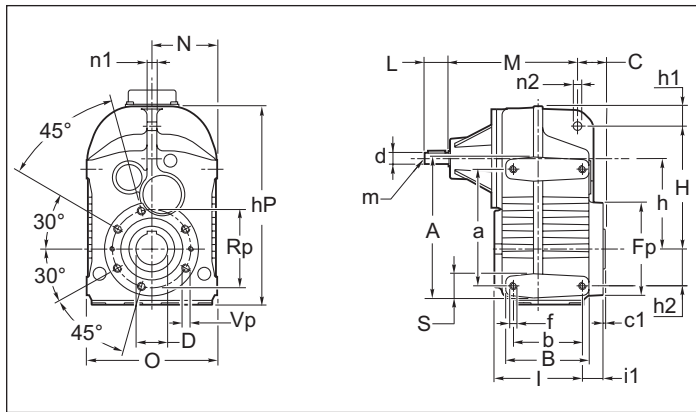

PRF

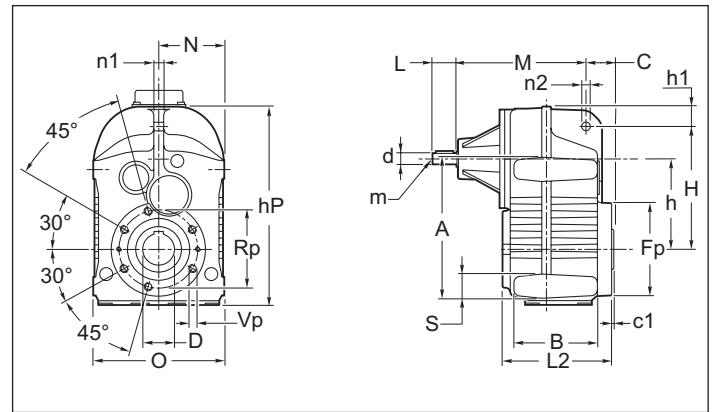

PRP F1 - F2

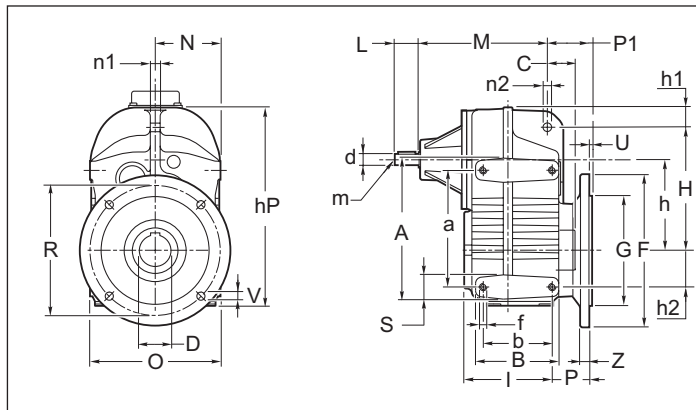

PRF F1 - F2

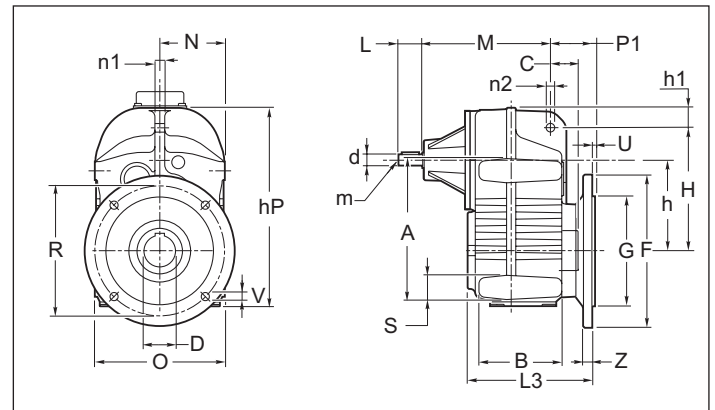

PRP P

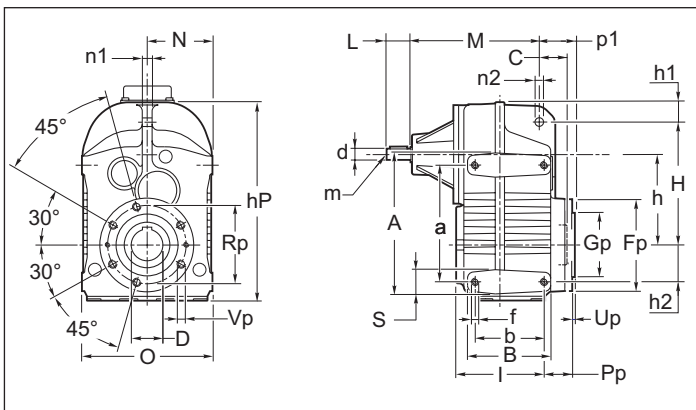

PRF P

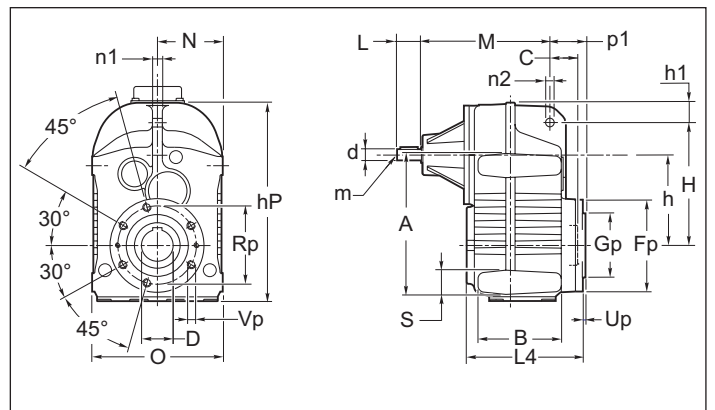

Particolare dei fori nella Flangia - "P"
Detail holes of the flange - "P"

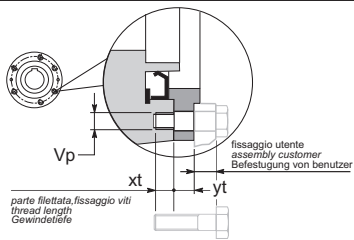

Per il fissaggio al riduttore con i fori "Vp" considerare la lunghezza delle viti adeguate, e che la quota "yt" non è filettata (vedi disegno).

When P-flange is used please consider that the threads "Vp" are in gearbox and that distance "yt" does not have a thread (see drawing).

Bei Verwendung des P-Flansches ist zu beachten, daß sich die Gewinde im Getriebegehäuse befinden und daß Maß "yt" kein Gewinde besitzt. Details siehe Zeichnung.

	Vp	xt	yt
63	N°6 M6	12	11,5
71	N°6 M8	15	11
90	N°6 M12	18	12
112	N°6 M14	23	14



1.8 Dimensioni

1.8 Dimensions

1.8 Abmessungen









P.P P.F	a	A	b	B	C	c1	d j6	D H7	f	h	hP	H	h1	h2	l	l1	L	L2	L3	L4	m	M	N
63	115	135	77	95	31.5	2.5	16	30 (25) (28)	N° 8 M8x12	103.5	240	152	23.5	31	96.5	20	40	116.5	143	128	M6	148.5 2 st.	P.F 84.5
								136.5 3 st.														P.P 82.5	
71	145	170	93	120	35	3	16	35 (30) (32)	N° 8 M10x15	117	268	165	26	43	119	28	40	147	175	158	M6	163.5 2 st.	P.F 92
								182 3 st.														P.P 90	
90	190	220	112	135	45	3.5	19	40 (42) (45) (48)	N° 8 M12x17	147	324	200	33	60	143	33.5	40	176.5	203.5	188.5	M6	187 2 st.	P.F 109
								209 3 st.														P.P 106	
112	240	280	140	166	50	4	24	50 (55)	N° 8 M16x23	184	400	255	35.5	70	172.5	32.5	50	205	246	219	M8	223.5 2 s	P.F 138
								t. 239 3 st.														P.P 135	
125	310	350	125	158	44.5	2.5	28	55 (60) (50)	N°8 N16x30	222	502	310	45	100	157	27	60	169	247	169	M8	252	152.5

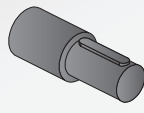

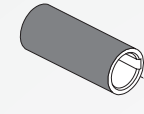
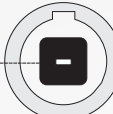
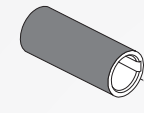
P.P P.F	n1	n2	O	p1	P1	S	Fp	Gp	Pp	Rp	Up	Vp	F	G g6	P	R	U	V	Z	
63	12	14	P.F 169	43.5	59	20	105	80	31.5	90	3	N°6 M6x12	F1	160	110	46.5	130	3.5	N°4 φ 9	10
			P.P 165										F2	—	—		—	—		
71	12	14	P.F 184	46	63.5	25	120	80	39	100	3	N°6 M8x14	F1	200	130	56	165	3.5	N°4 φ 11	12
			P.P 180										F2	160	110		130	3.5	N°4 φ 9.5	10
90	16	14	P.F 218	57	72	30	150	105	45.5	125	3.5	N°6 M12x18	F1	250	180	60.5	215	4	N°4 φ 13.5	15
			P.P 212										F2	—	—		—	—	—	—
112	20	22	P.F 276	63	91	40	175	125	46.5	150	3.5	N°6 M14x21	F1	300	230	73.5	265	4	N°4 φ 13.5	16
			P.P 270										F2	—	—		—	—	—	—
125	24	22	P.P 305	42	110	40	200	140	21	165	6	N°8 M12x20	F1	350	250	90	300	5	N° ø18	18

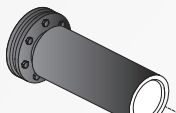
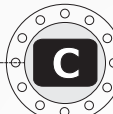
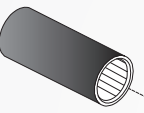
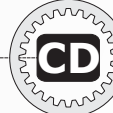
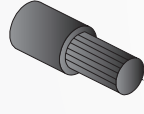

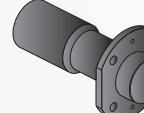
ESTREMITA USCITA - Accessori - Opzioni
OUTPUT CONFIGURATIONS - Accessories - Options
ENDEN DER AUSGANGSWELLEN - Zubehör - Optionen

STM
team

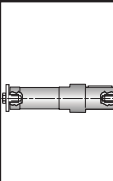
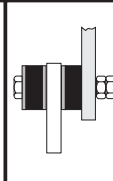
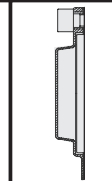
	 	Output shaft	E29
		Hollow shaft	E30
		Quick Locking	E32
		Hollow output shaft with shrink disc	E34
		Splined hollow shaft	E35
	 	Splined output shaft without broached flange	E36
	 	Splined output shaft and broached flange	E38

				
AL	AV	PROT	RR	FF

**OPT - ACC. -
Accessories - Options** **E40**

STM
team

1.8.1 - ALBERI LENTI

1.8.1 - OUTPUT SHAFT

1.8.1 - ABTRIEBSWELLEN

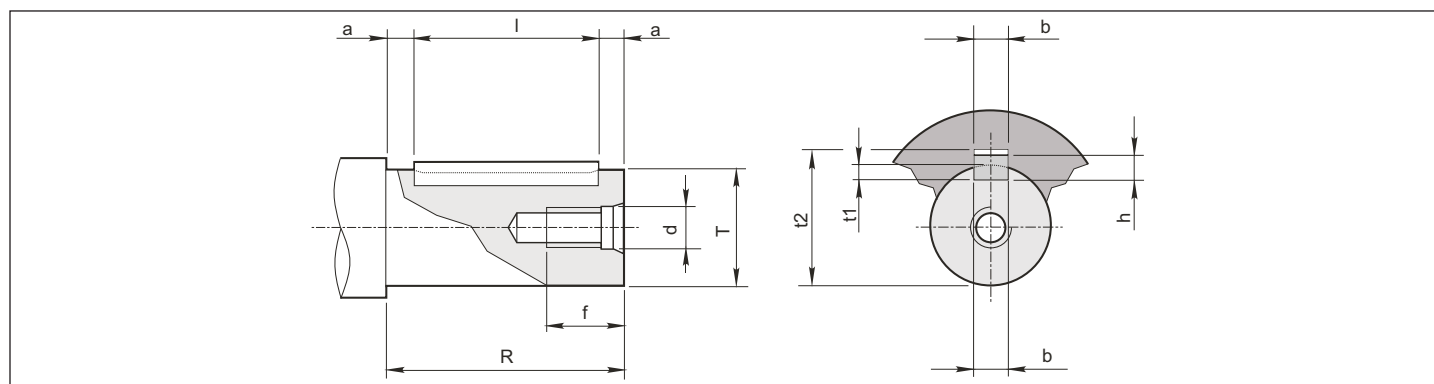
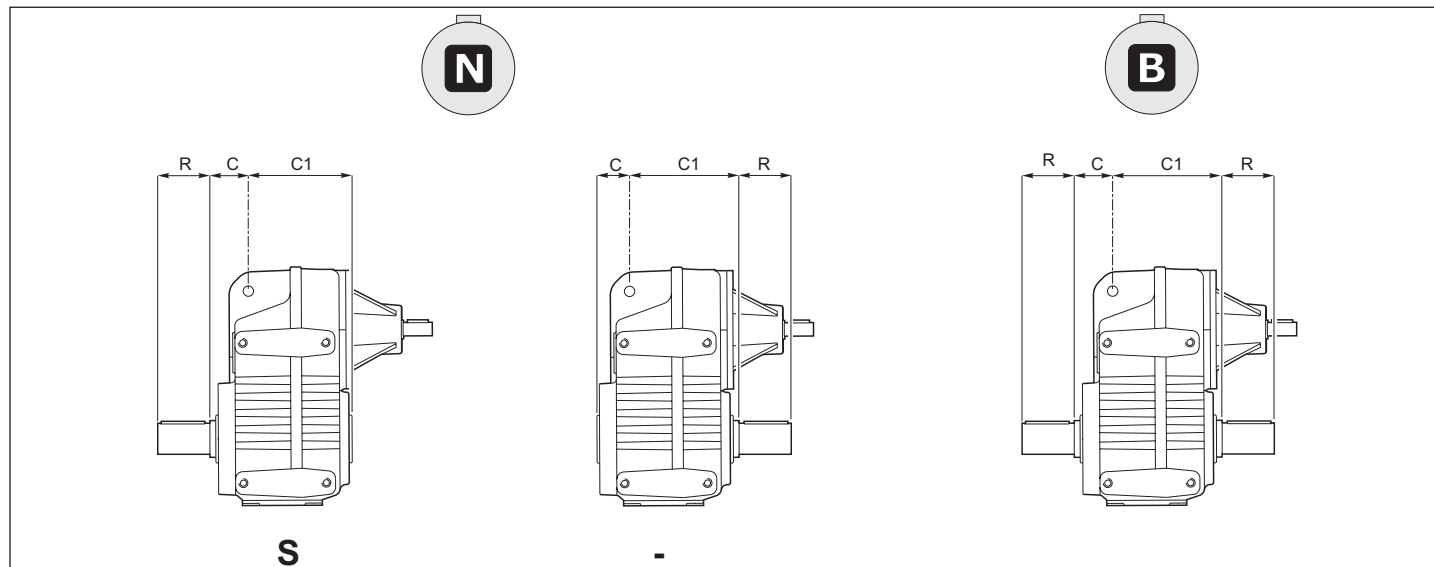

	Ø Albero Ø Shaft Ø Welle			Foro fil. testa Tapped hole Gewindebohrung Kopfi		Cava Keyway Nut			Estremità d'albero Shaft end Wellenende		Linguetta Key Federkeil
	T	C	C1	d	f	b	t1	t2	R	a	bxhxl
63	30 g6	31.5	88.5	M 10	25	8	4	33.3	60	5	8X7X50
71	35 g6	35	115	M 10	25	10	5	38.3	70	5	10x8x60
90	40 g6	45	135	M 10	25	12	5	43.3	80	5	12x8x70
112	50 g6	50 - N 51 - N	160 - N 161 - B	M 12	32	14	5.5	53.8	100	5	14x9x90
125	55 g6	44.5	135.5	M 12	32	16	6	59.3	110	5	16x10x100

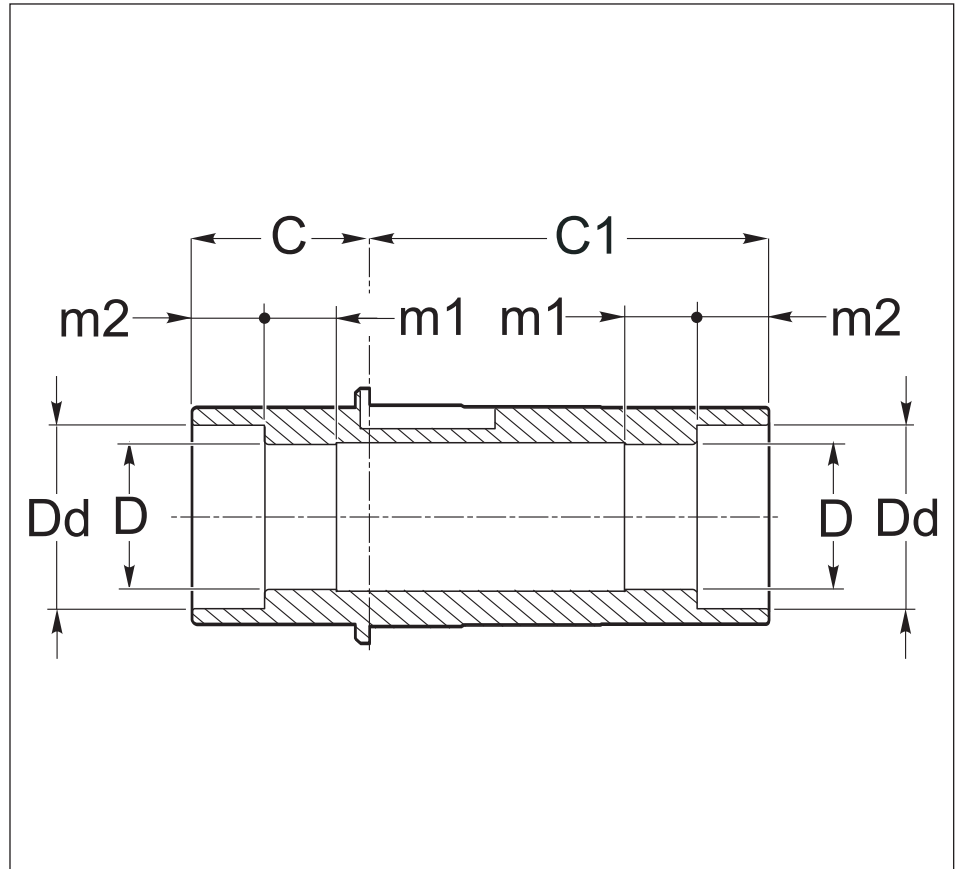
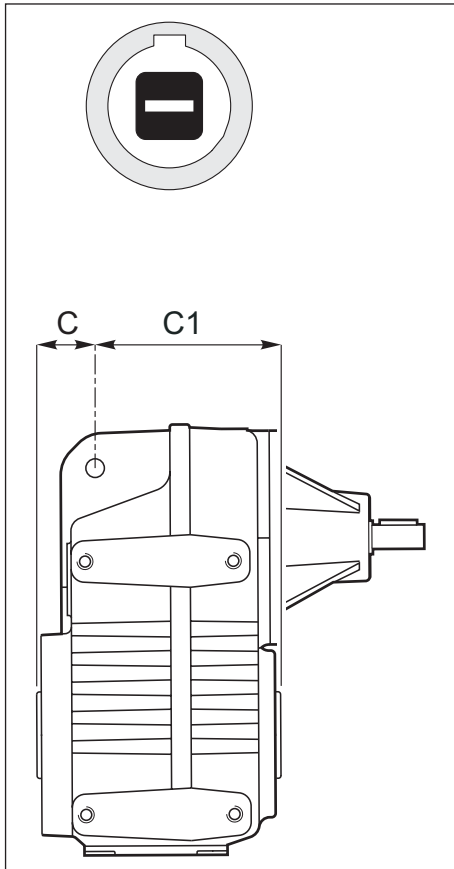

	63	71	90	112
C	31.5	35	45	50
C1	88.5	115	135	160
D	30	35	40	50
H7	(25) (28)	(30) (32)	(42) (45) (48)	(55)
m1	15	30	35	35
m2	15	15	20	25
Dd	38	43	55	61

Perno macchina / Customer shaft / Maschinachse

	d1 h6	m3	Lm	m	H	L min	P	R	Ra	Rb
63	30 (25) (28)	20	25 (25) (25)	M 10 (M 8) (M 10)	88	50	29.8 (24.8) (27.8)	36		
71	35 (30) (32)	35	25	M 10	118	60	34.8 (29.8) (31.8)	42.5		
90	40 (42) (45) (48)	40	25	M 10	138	90	39.8 (41.8) (44.8) (47.8)	54.5		
112	50 (55)	35	32	M 12	158	110	49.8 (54.8)	60		

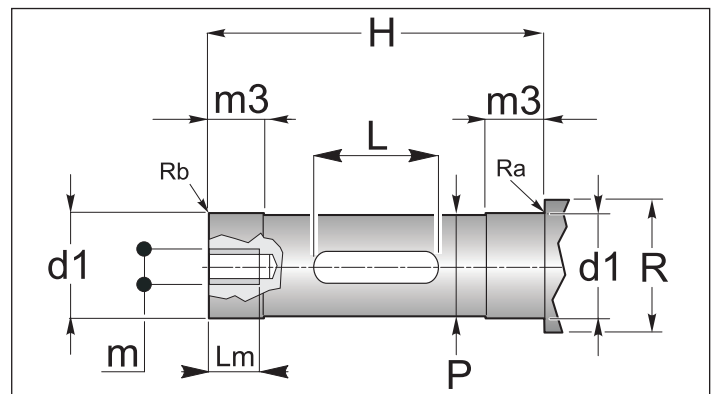

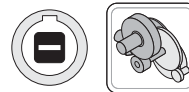

1.8.1 - ALBERI LENTI

1.8.1 - OUTPUT SHAFT

1.8.1 - ABTRIEBSWELLEN

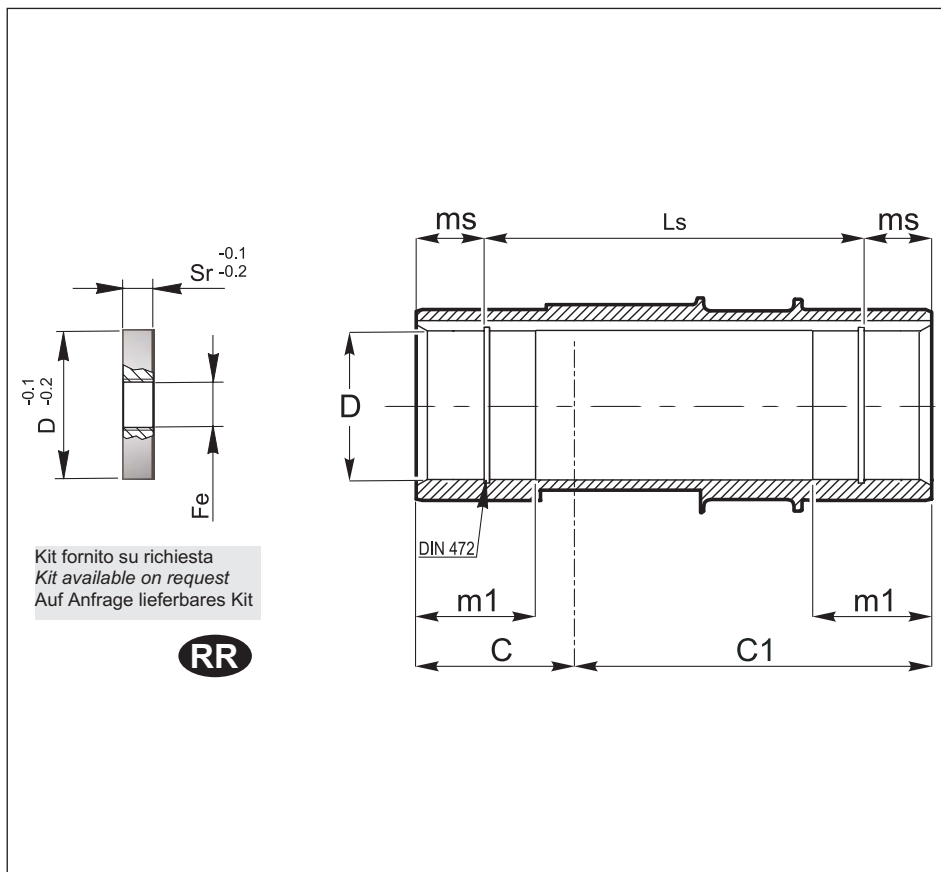
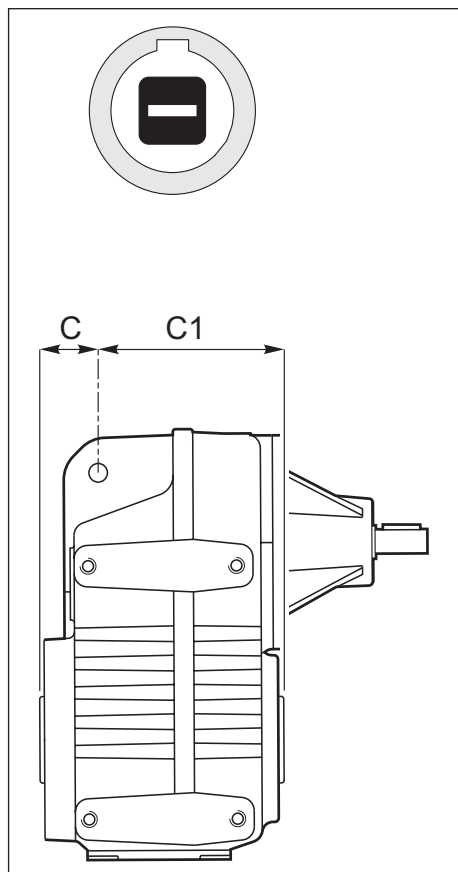

	125
C	44.5
C1	135.5
D	55
H7	(60)
	(50)
m1	55
ms	17.5
Ls	145

Perno macchina / Customer shaft / Maschinachse

	d1 h6	m3	Lm	m	H	L min	P	R	Ra	Rb
125	55 (60) (50)	60	32	M 12	142	110	54.8 (59.8) (49.8)	65 (70) (60)		

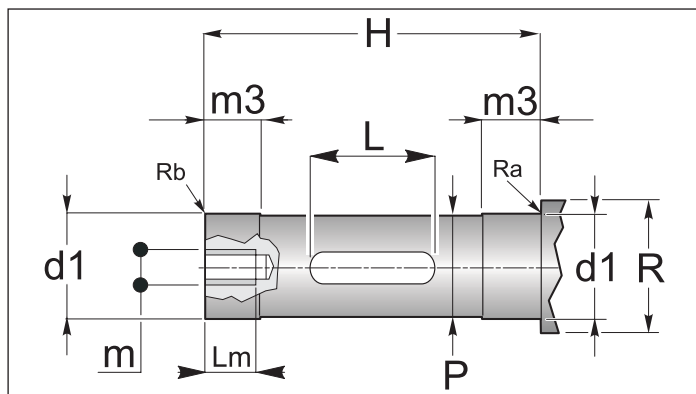

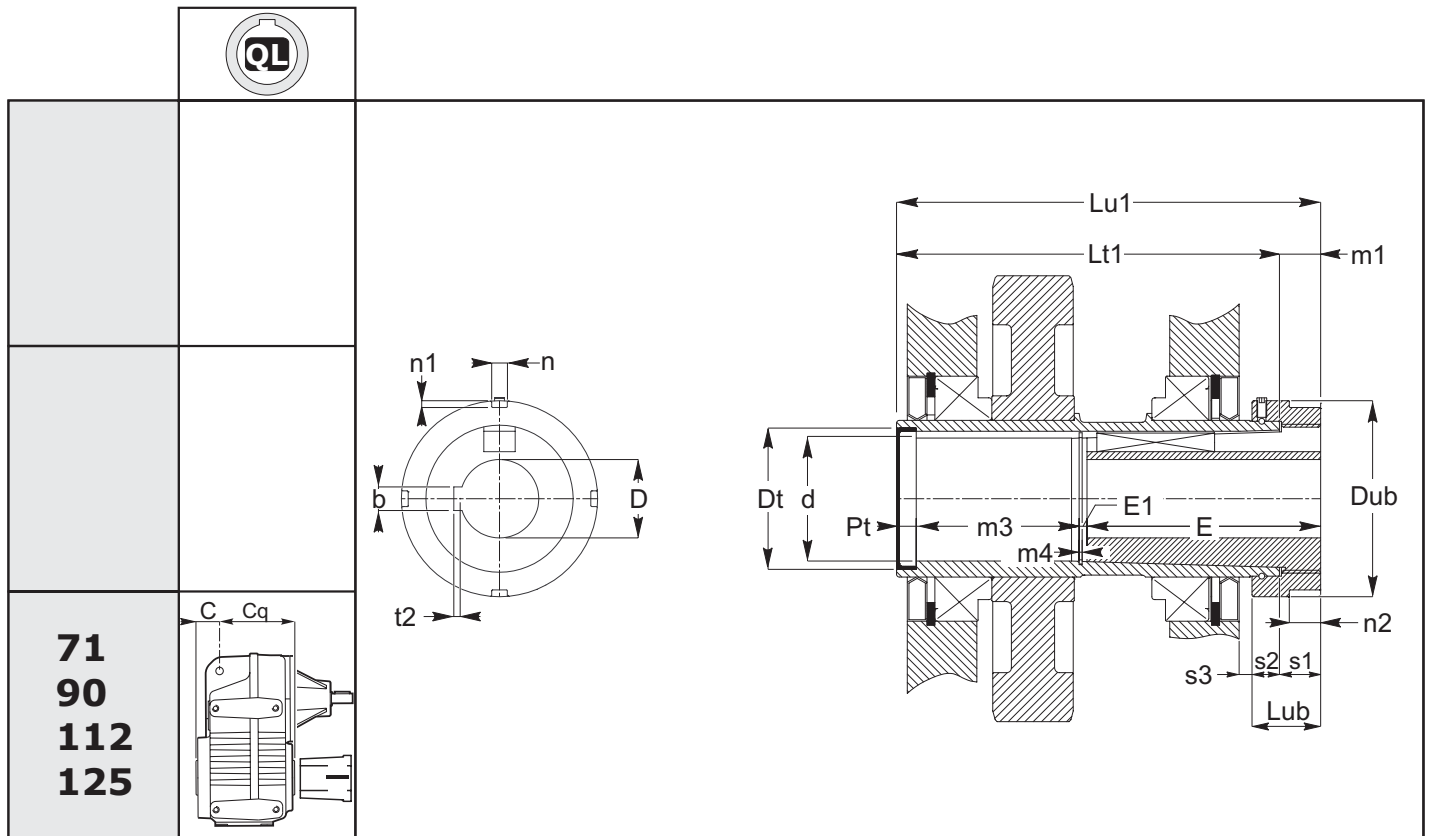

	71	90	112	125
C	35	45	50	44.5
Cq	111	126	141	135.5
d	35.2	49.2	54.2	60.2
dt	47	62	65	72
Dub	70	85	90	100
E	91	121	131	131
E1	3.5	3.5	3.5	3.5
Lt1	165	195	225	195
Lu1	186	216	246	216
Lub	35	35	35	35
m1	21	21	21	21
m3	84.5	83.5	101.5	71.5
m4	1.7	1.7	1.7	1.7
n2	15	15.5	15.5	16
s1	21	21	21	21
s2	14	14	14	14
s3	8	8	8.5	6.5
D		25		35
H7	20	30	30	40
	25	35	35	45
	30	38	40	48
		40	45	50
		42	50	55
		45		
		48		
n	6	7	7	8
n1	2.5	3	3	3.5
b	UNI 6604			
t2				

Perno macchina / Customer shaft / Maschinachse

	C	de h6	G	L	Lu	R	b1	t1
71	1	(20)	10	40	90	5		
		(25)	10	50				
		(30)	10	60				
90	1.5	(25)	10	50	120	5		
		(30)	10	60				
		(35)	10	70				
		(38)	10	70				
		(40)	5	80				
		(42)	5	80				
112	1.5	(45)	5	90	130	5		
		(48)	5	90				
		(30)	10	60				
		(35)	10	70				
		(40)	10	80				
125	1.5	(45)	5	90	130	5		
		(48)	10	90				
		(50)	5	100				
		(35)	10	70				
		(40)	10	80				

UNI 6604

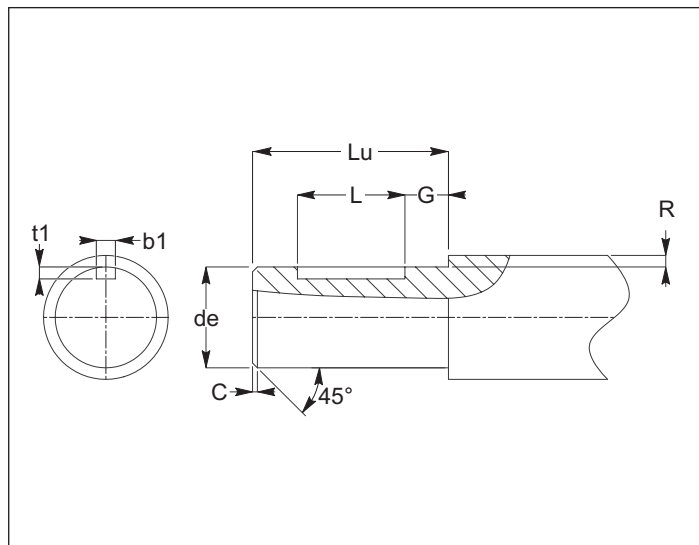



1.8.1 - ALBERI LENTI

1.8.1 - OUTPUT SHAFT

1.8.1 - ABTRIEBSWELLEN

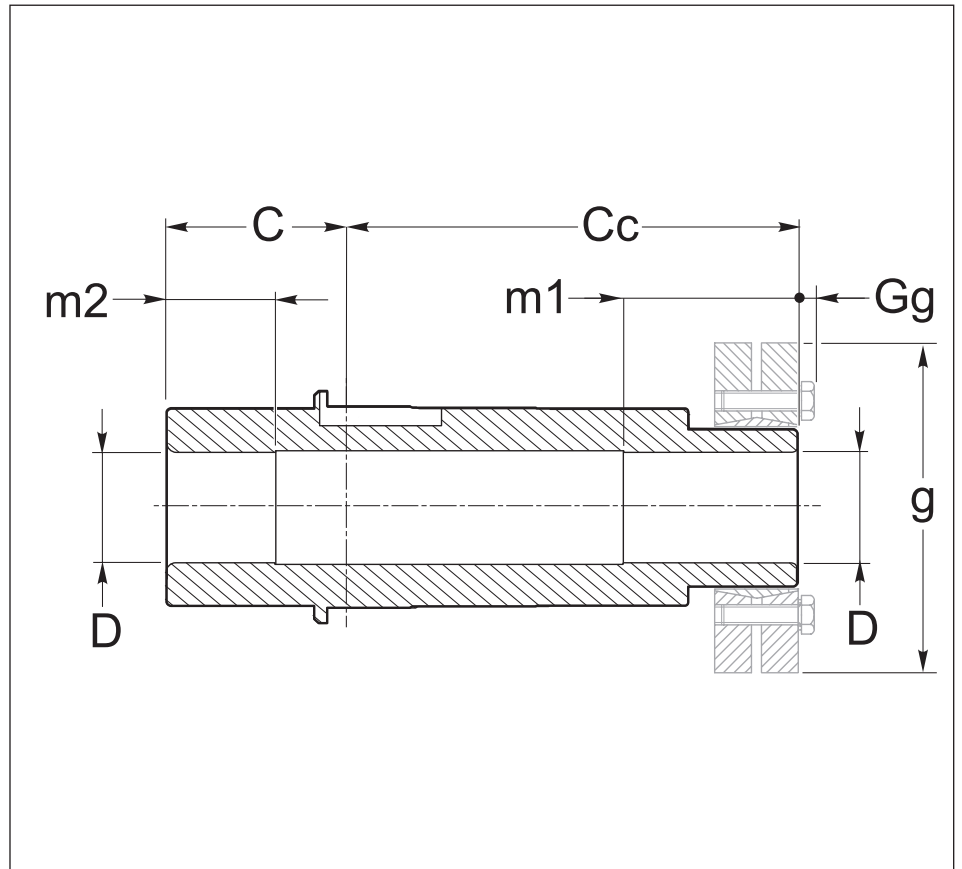
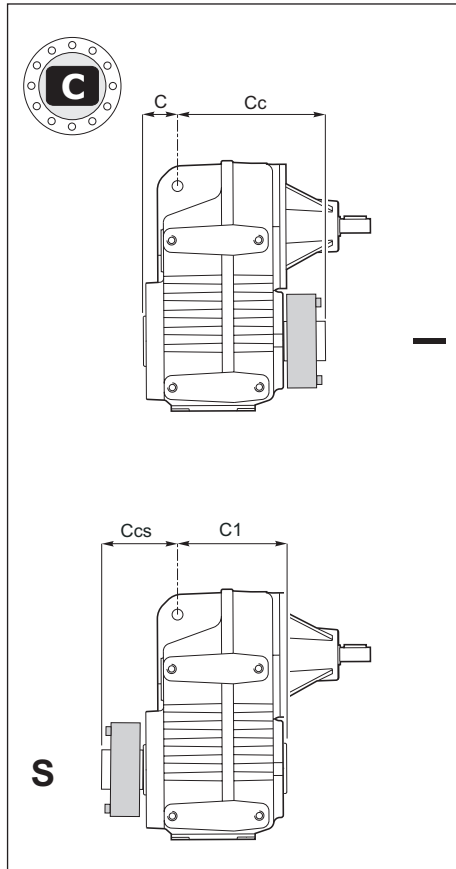

	63	71	90	112	125
C	31.5	35	45	50	44.5
Cc	113.5	140	165	195	170.5
C1	88.5	115	135	160	135.5
Ccs	56.5	60	75	85	79.5
D H7	30	35	40	50	55
m1	40	40	50	55	60
m2	25	25	30	40	50
g	72	80	90	110	115
Gg	4	4	6	1	4

Perno macchina / Customer shaft / Maschinachse

	d1 h6	H	m3	m4	P	R	Ra	Rb
63	30	145	45	30	29.8	36		
71	35	175	45	30	34.8	42.5		
90	40	210	55	35	39.8	54.5		
112	50	245	60	45	49.8	60		
125	55	215	65	55	54.8	65		

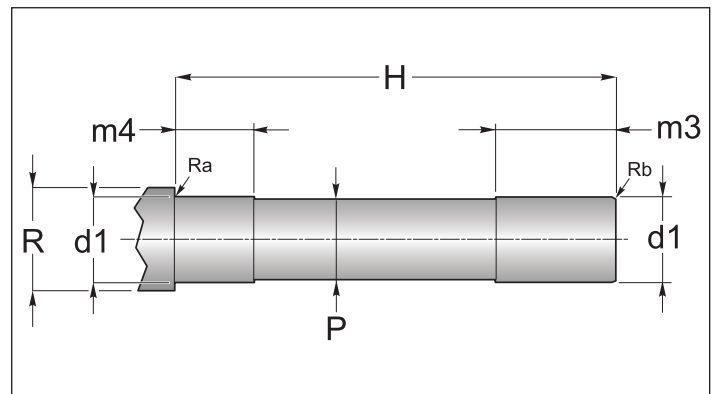

1.8.1 - ALBERI LENTI

1.8.1 - OUTPUT SHAFT

1.8.1 - ABTRIEBSWELLEN

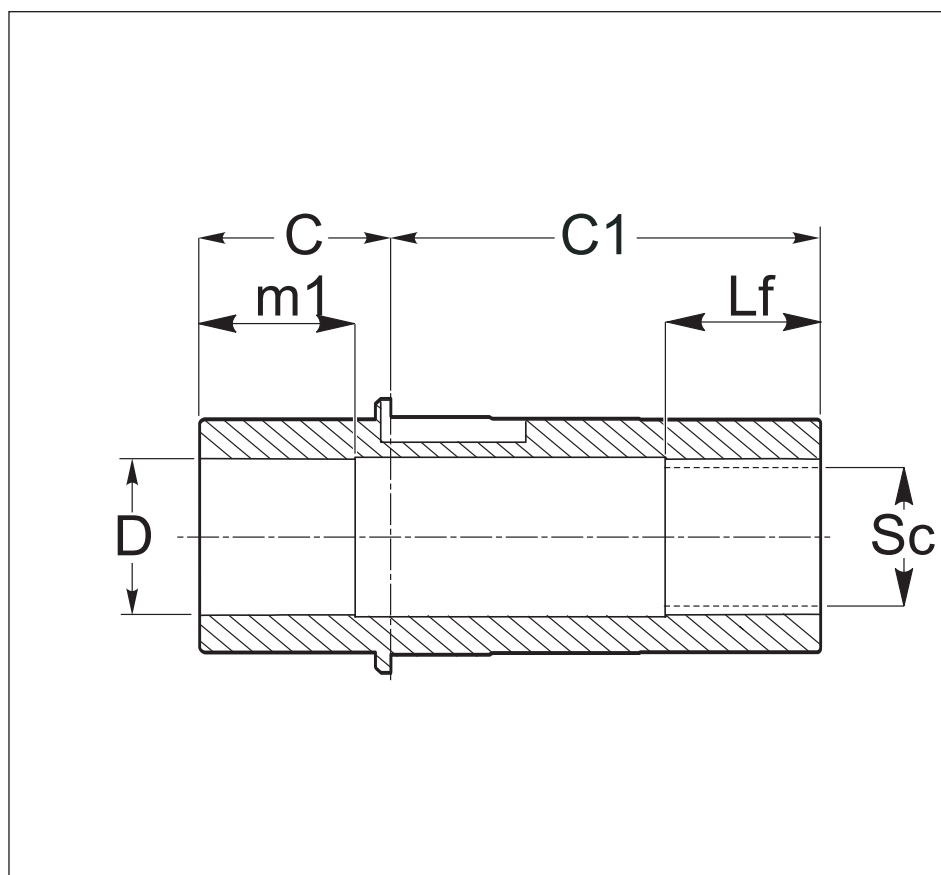
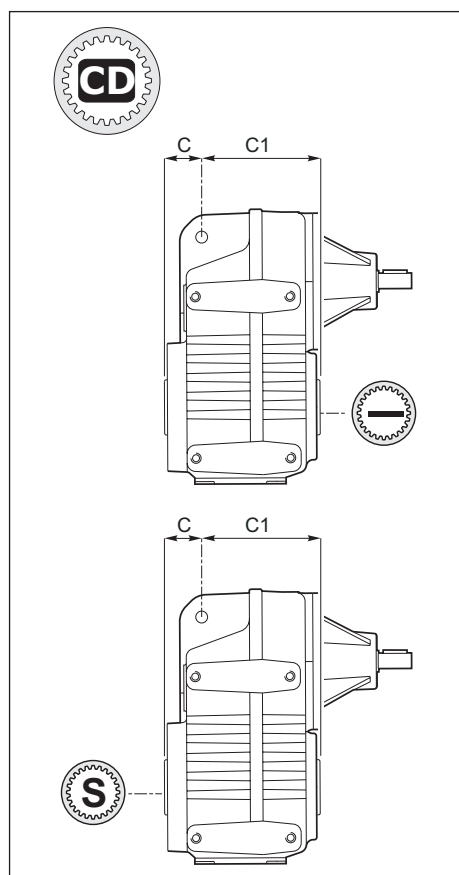

	63	71	90	112	125
C	31.5	35	45	50	44.5
C1	88.5	115	135	160	135.5
D H7	30	37	45	55	57
m1	35	40	55	60	60
Lf	35	45	55	65	60
Sc	28 x 25 DIN 5482	35 x 31 DIN 5482	40 x 36 DIN 5482	50 x 45 DIN 5482	55x50 DIN 5482

Perno macchina / Customer shaft / Maschinachse

	d1 h6	m 3	H	P	R	R _a	R _b	Sc	F	Lf	Lm	m
63	30	30	117	29	40	0.5	1x45°	45	35	20	M8	
71	37	35	147	36	48	0.5	1x45°	50	40	25	M10	
90	45	50	177	42	55	0.5	1x45°	65	55	25	M10	
112	55	55	210	52	65	1	1.5x45°	75	65	35	M12	
125	57	55	175	56	75	1	1.5x45°	70	60	35	M12	

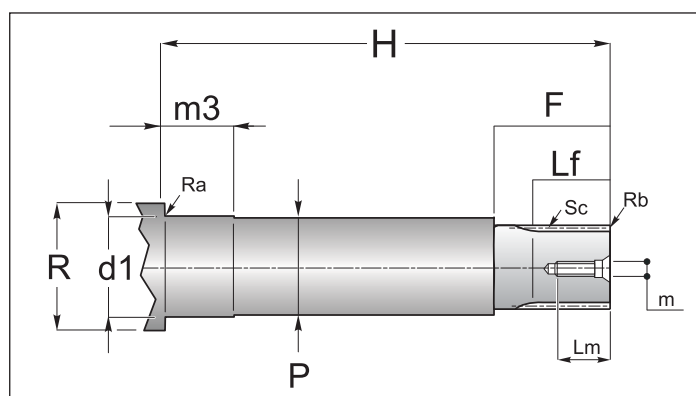

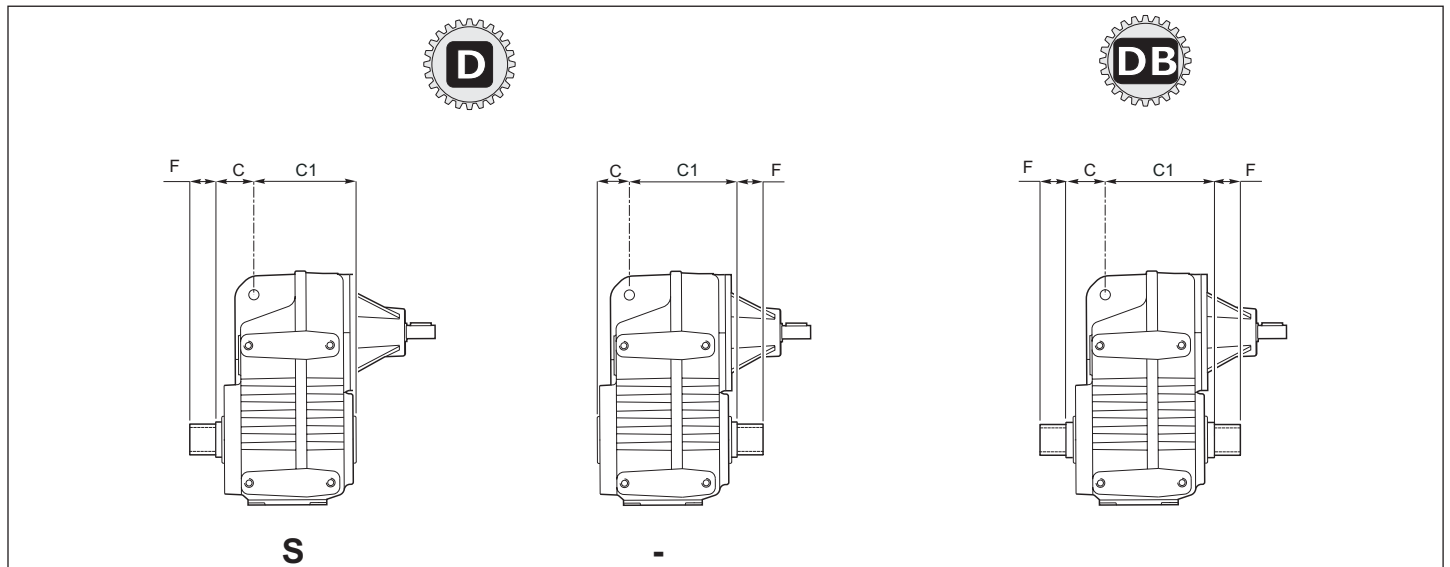

	C	C1	de (h10)	F	Profilo scanalato / Splined profile / Keilprofil					
					Sc	Z	mn	α	dc (f7)	Sp
63	31.5	88.5	Look Drawing			35 x 31 DIN 5482				Look Drawing
71	35	115				35 x 31 DIN 5482				
90	45	135				40 x 36 DIN 5482				
112	50	160				58 x 53 DIN 5482				
125	44.5	135.5				70x64 DIN5482				

63-71

FF - Kit fornito su richiesta
Kit available on request
Auf Anfrage lieferbares Kit

90

FF - Kit fornito su richiesta
Kit available on request
Auf Anfrage lieferbares Kit



1.8.1 - ALBERI LENTI

1.8.1 - OUTPUT SHAFT

1.8.1 - ABTRIEBSWELLEN

<h1>112</h1>		<p>FF - Kit fornito su richiesta Kit available on request Auf Anfrage lieferbares Kit</p>
<h1>125</h1>		<p>FF - Kit fornito su richiesta Kit available on request Auf Anfrage lieferbares Kit</p>



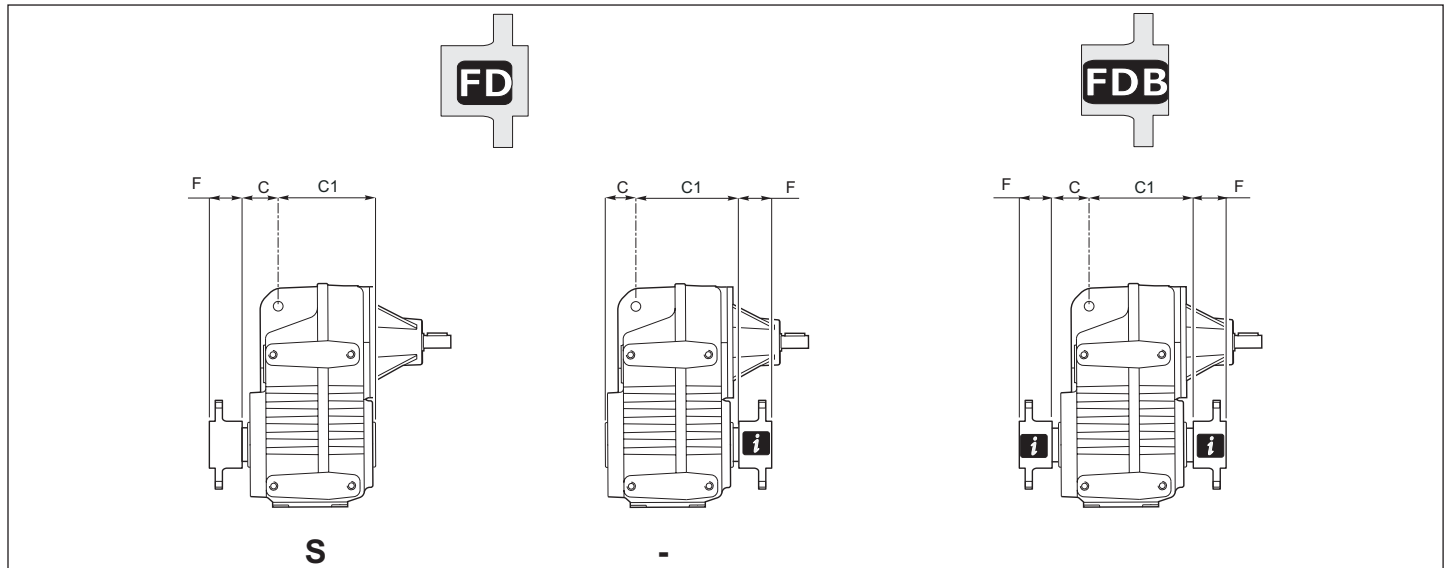

*Contattare il ns. servizio tecnico / Contact our technical dept / Wenden Sie sich an unseren technischen Service

Dimensioni generali / General dimensions / Allgemeine Abmessungen														
	de	∅ A	∅ B	∅ C	∅ C1	∅ Ce f8	N° Fori holes Anzahl der Bohrungen	∅ D	E	F	G	H	I	N h9
63	Look Drawing			31.5	88.5									
71				35	115									
90				45	135									
112				50	160									
125				44.5	135.5									

63-71				FF - Kit fornito su richiesta Kit available on request Auf Anfrage lieferbares Kit
	90			



1.8.1 - ALBERI LENTI

1.8.1 - OUTPUT SHAFT

1.8.1 - ABTRIEBSWELLEN

<h1>112</h1>			<p>FF - Kit fornito su richiesta Kit available on request Auf Anfrage lieferbares Kit</p>
<h1>125</h1>			<p>FF - Kit fornito su richiesta Kit available on request Auf Anfrage lieferbares Kit</p>





1.9 OPT - ACC. - Accessori - Opzioni

1.9 OPT - ACC. - Accessories - Options

1.9 OPT - ACC. Zubehör - Optionen

AV

ANTIVIBRANTE VKL

RUBBER BUFFER VKL

GUMMIHÜLSE VKL

Per riduttori e motoriduttori pendolari.

For shaft mounted gearboxes and geared motors.

Für aufsteckgetriebe und aufsteckgetriebe-motoren.

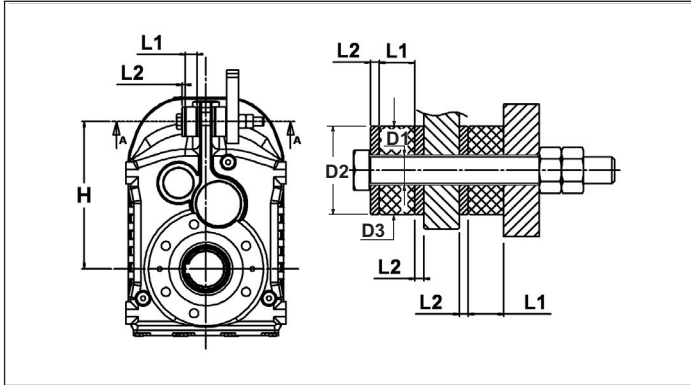

P.P - P.F	D1	D2	D3	L1	L2	H
63	12.5	40	40	16	4	152
71	12.5	40	40	16	4	165
90	12.5	40	40	16	4	200
112	21	60	60	22	8	255
125	21	60	60	22	8	310

AL

AL - ALBERO LENTO SPORGENTE

AL - SINGLE OUTPUT SHAFTS

AL - EINSEITIGE ABTRIEBSWELLEN

Tutti i riduttori sono forniti con albero lento cavo. A richiesta, possono essere forniti kit di montaggio per alberi sporgenti comprensivi di linguette, rondelle e viti di fissaggio. Le dimensioni delle linguette sono conformi alle norme UNI 6604-69.

All gearboxes are supplied with hollow output shaft. On request there are available also assembly kits including output shafts, keys, washers and assembly screws. The dimensions of the keys are conform with UNI 6604-69.

Alle Getriebe werden mit Abtriebshohlwelle geliefert. Auf Anfrage sind auch Montagekits inklusive Abtriebswellen, Paßfedern, Unterlegscheiben und Montageschrauben erhältlich. Die Abmessungen der Paßfedern sind konform mit der UNI 6604-69.

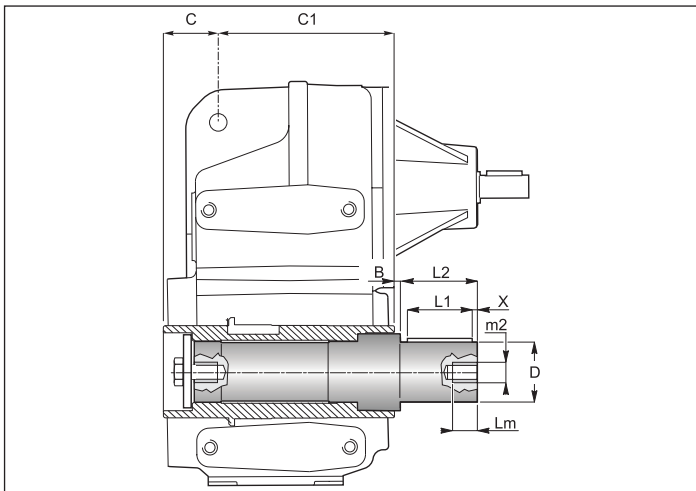

63-71-90-112

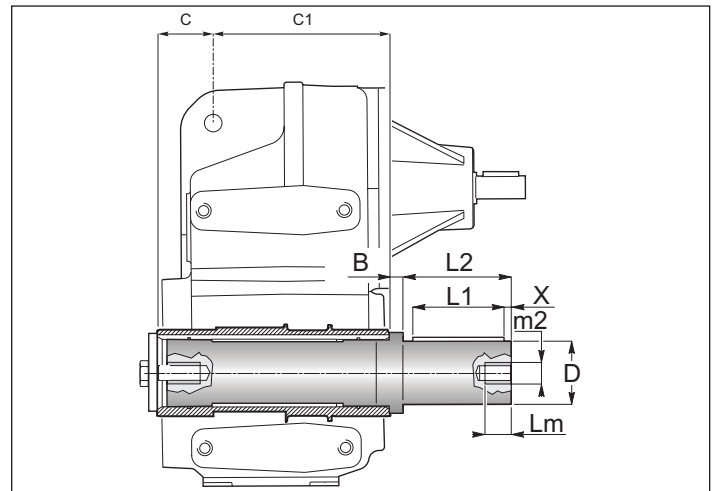

125

	B	C	C1	D g6	m ₂	L ₁	L ₂	L _m	X
63*	1	31.5	88.5	30	M10	50	60	25	5
71*	1	35	115	35	M10	60	70	25	5
90*	1	45	135	40	M10	70	80	25	5
112*	1	50	160	50	M12	90	100	32	5
125*	26	44.5	135.5	55	M 12	100	110	32	5

* ATTENZIONE
L'albero lento sporgente è fornito per essere installato sulla versione del riduttore con albero **CAVO** con diametro **STANDARD**.

*ATTENTION
The output shaft is available only for standard hollow shaft diameter.

Achtung:
Die Einseitige Abtriebswelle wird fuer die Montage bei Getrieben mit Standart Hohlwelle geliefert.



1.9 OPT - ACC. - Accessori - Opzioni

1.9 OPT - ACC. - Accessories - Options

1.9 OPT - ACC. Zubehör - Optionen

PROT PROT. - Coperchio di protezione

PROT. - Protection cover

PROT - Schutzvorrichtungdeckel

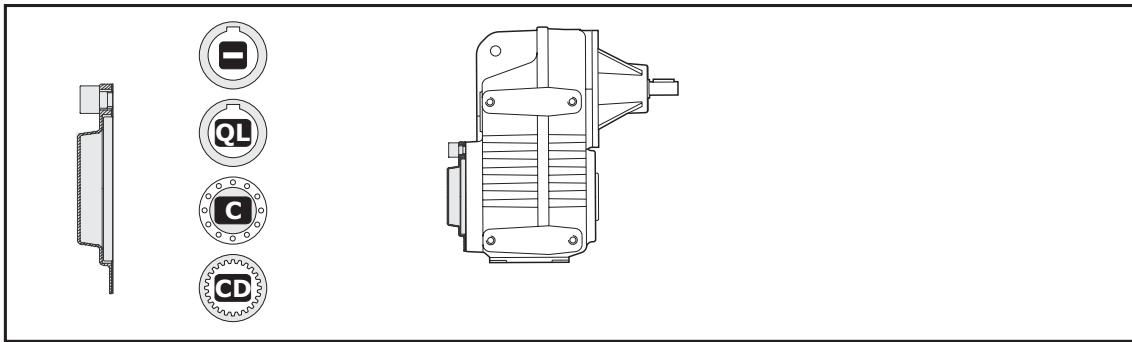

1.10 Linguette

1.10 Keys

1.10 Paßfedern

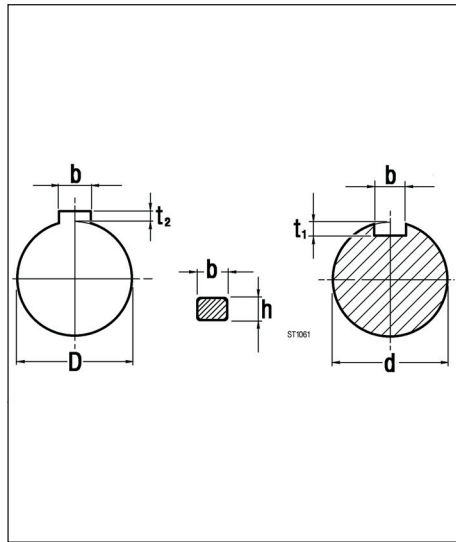

Albero entrata
Input shaft
Antriebswelle

Albero uscita
Output shaft
Abtriebswelle

Tab. 4.17

d	bxh	t1	
			0/ +0.1
16	5x5	3	
19	6x6	3.5	
24	8x7	4	0/ +0.2

D	bxh	t2	
			0/ +0.2
25	8x7	3.3	
28	8x7	3.3	0/ +0.2
30	8x7	3.3	0/ +0.2
32	10x8	3.3	0/ +0.2
35	10x8	3.3	0/ +0.2
40	12x8	3.3	0/ +0.2
42	12x8	3.3	0/ +0.2
45	14x9	3.8	0/ +0.2
48	14x9	3.8	0/ +0.2
50	14x9	3.8	0/ +0.2
55	16x10	4.3	0/ +0.2
60	18x11	4.4	0/ +0.3



